

2012/13



MA[&]DE

A TRAVÉS DE LA INVESTIGACIÓN Y LA APLICACIÓN DE TECNOLOGÍAS DE VANGUARDIA, LA MATERIA ASUME FORMAS Y COLORES QUE EVOCAN, CADA VEZ, LA FUERZA, LA PUREZA Y LA CREATIVIDAD DE LA NATURALEZA. PASIÓN E INNOVACIÓN ENCUENTRAN NUEVOS RECORRIDOS EXPRESIVOS.

DIE JUNGE MARKE MA[&]DE ZEUGT VOM STIL UND GESCHMACK, VON DENEN DIE ARBEIT VON DESIGNERN UND TECHNIKERN BESTIMMT WIRD, QUALIFIZIERTE UND ENGAGIERTE FACHLEUTE, DIE FÜR EINEN ERFOLG VERANTWORTLICH SIND, DER IN ANGESEHENEN WETTBEWERBEN, VON STIFTUNGEN UND AUF INTERNATIONALEN DESIGNAUSSTELLUNGEN ANERKENNUNG GEFUNDEN HAT.

НОВЫЙ БРЕНД МА[&]ДЕ ОТЛИЧАЕТСЯ СВОИМ СТИЛЕМ И ВКУСОМ, КОТОРЫЕ СОПРОВОЖДАЮТ ВО ВРЕМЕНИ РАБОТЫ ДИЗАЙНЕРОВ И СВЕТОТЕХНИКОВ - СПЕЦИАЛИСТОВ, КОТОРЫЕ ОБЛАДАЮТ НЕОБХОДИМОЙ КВАЛИФИКАЦИЕЙ И СТРЕМЛЕНИЕМ ДЛЯ ДОСТИЖЕНИЯ УСПЕХА В РАЗЛИЧНЫХ КОНКУРСАХ И ВЫСТАВКАХ И ПРИЗНАНИЯ ПРЕСТИЖНЫМИ ОРГАНИЗАЦИЯМИ.



2011

LAMA

DESIGN MIRCO CROSATTO

SELEZIONATI REDDOT 2011
/ SELECTED BY REDDOT 2011



reddot design award





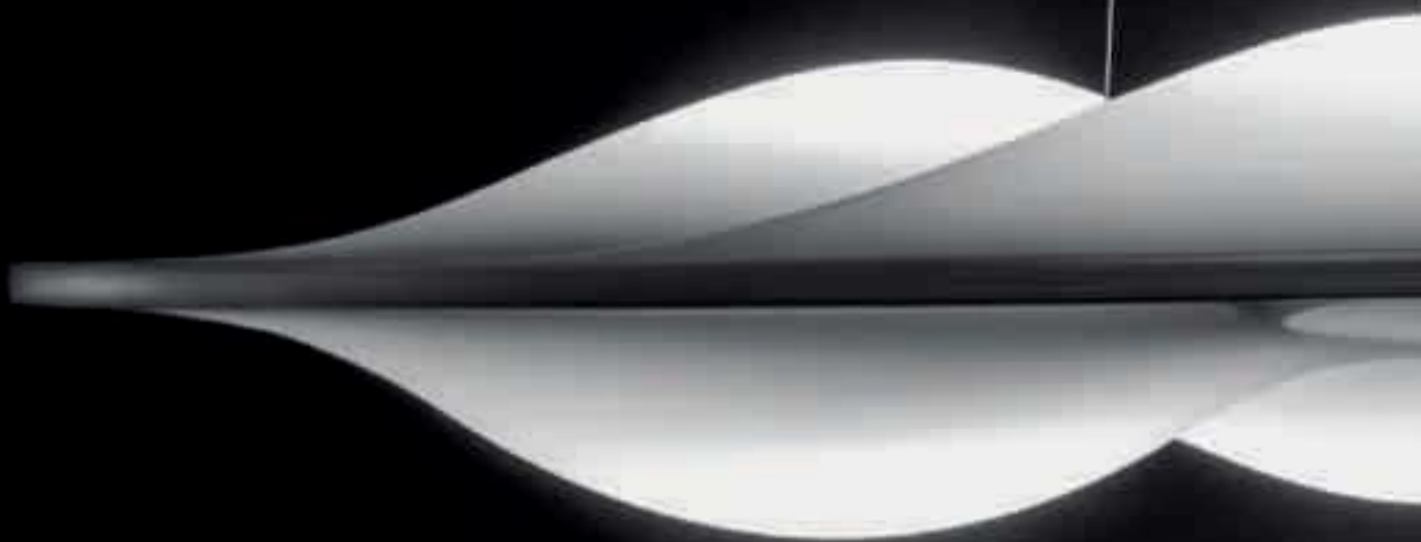

Circle Wave gioca con le forme attraverso un disegno unico: una creazione di luce ed ombra frutto della lavorazione accurata del materiale plastico e della performance di LED SMD di ultima generazione.

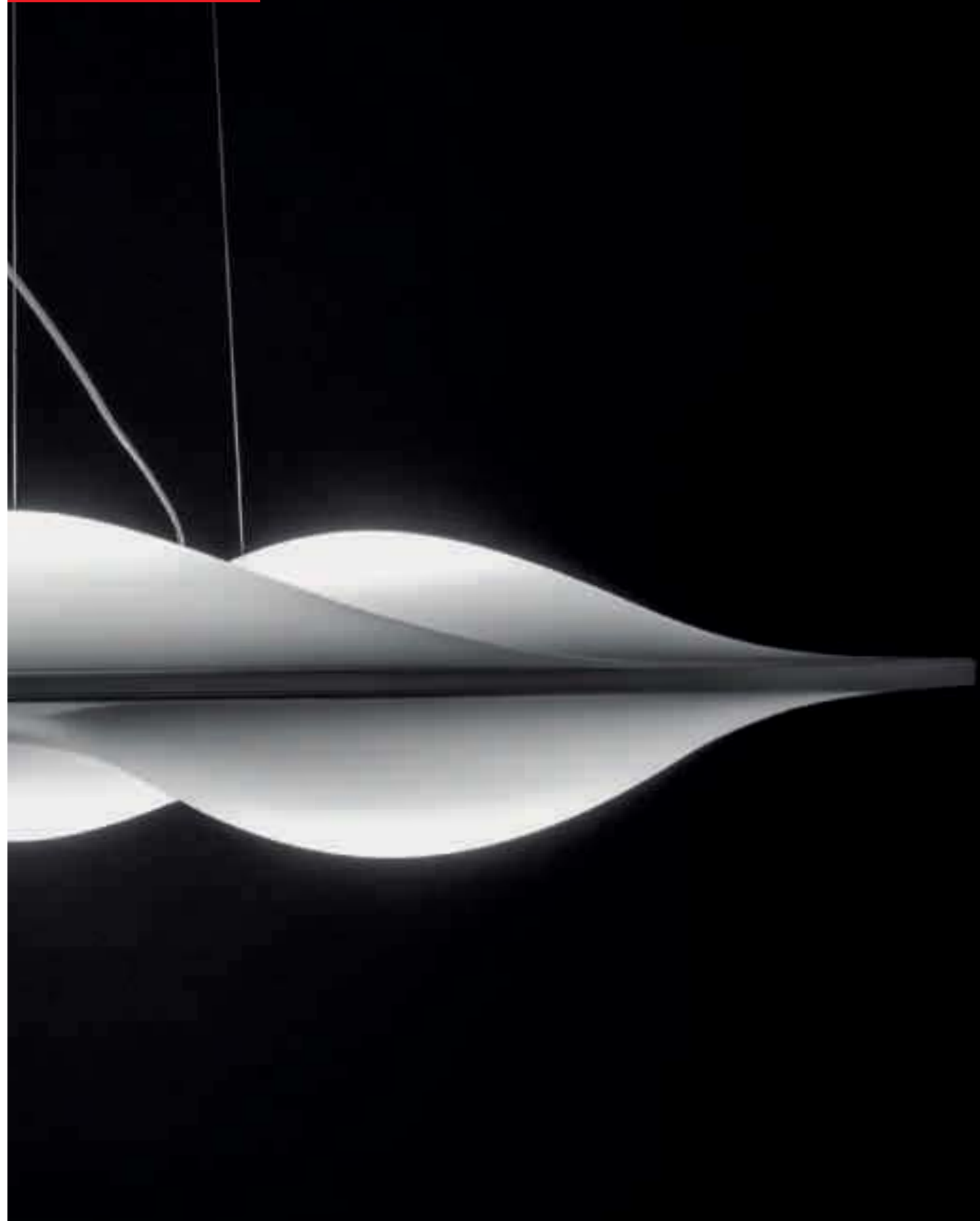

Circle Wave plays with forms through an unique drawing: a creation of light and shadow, fruit of the accurate manufacturing of the plastic and the performance of cutting-edge SMD LEDs.



Una lampada da soffitto in alluminio verniciato bianco raggrinzante, con un diffusore termoformato in PMMA satinato. La luce è a LED.

A ceiling luminaire made of wrinkled white-painted aluminium, with a thermoshaped, satin-finished PMMA diffuser. It features an LED light.

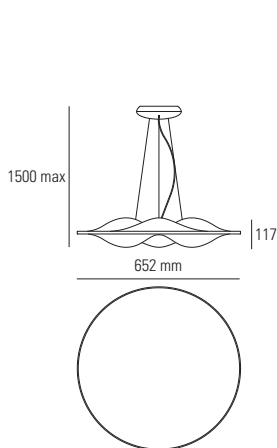

 DOPPIA EMISSIONE / DOUBLE EMISSION

7462 bianco satinato / satin white

LED 36W 240V
warm white 3000K 2700 lm

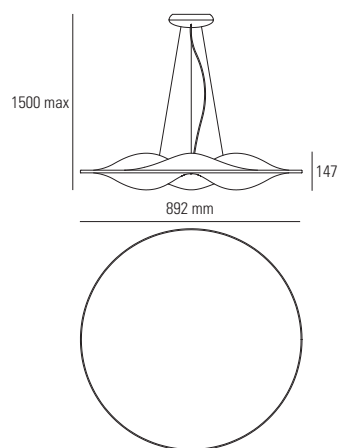

 DOPPIA EMISSIONE / DOUBLE EMISSION

7460 bianco satinato / satin white

LED 48W 240V
warm white 3000K 3600 lm



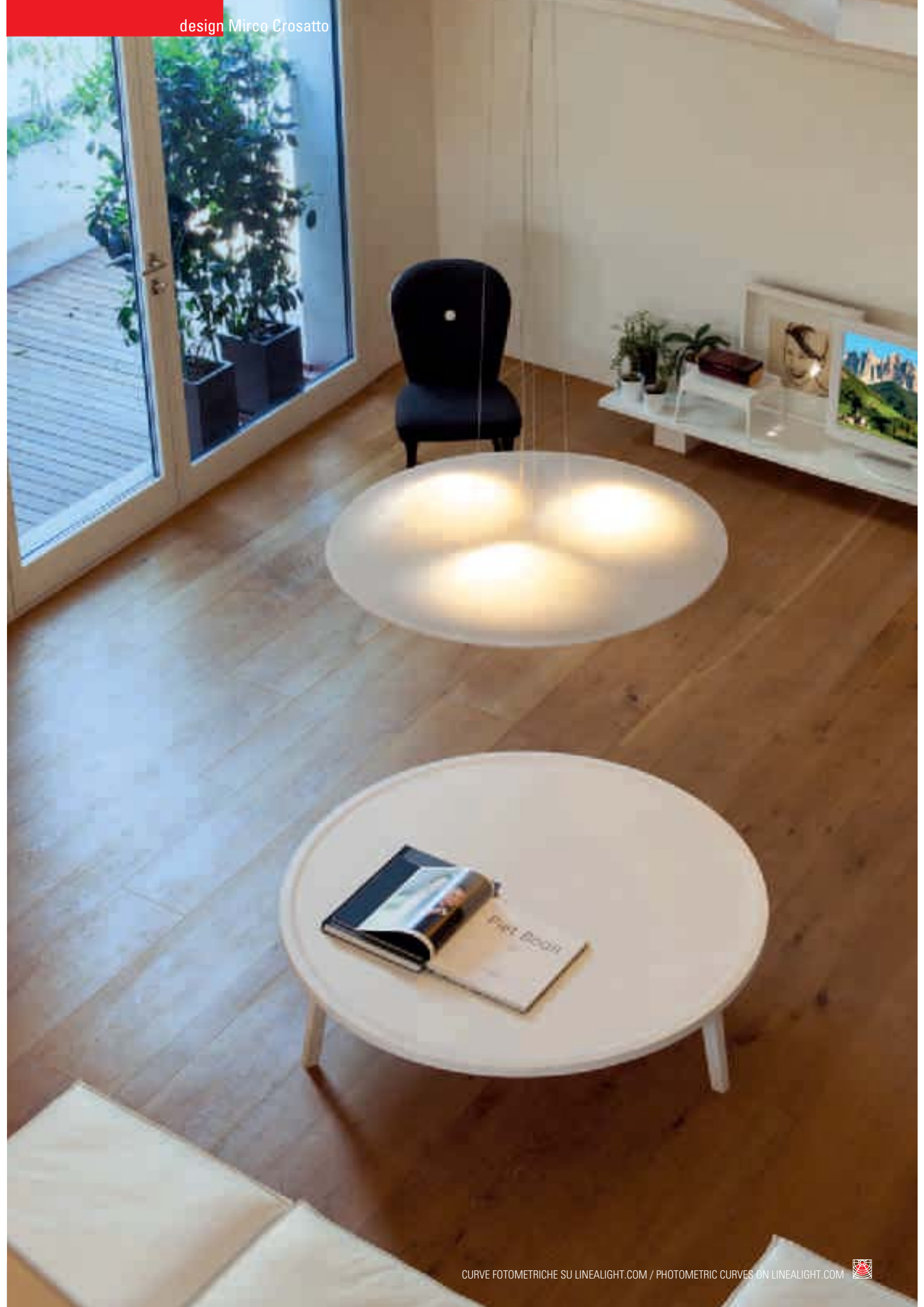

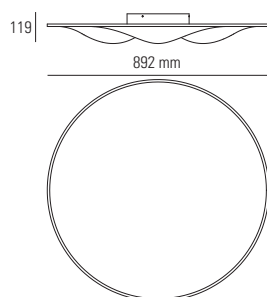

7461 bianco satinato / satin white
LED 48W 240V
warm white 3000K 3600 lm

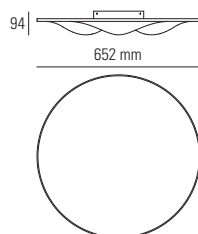

7463 bianco satinato / satin white
LED 36W 240V
warm white 3000K 2700 lm





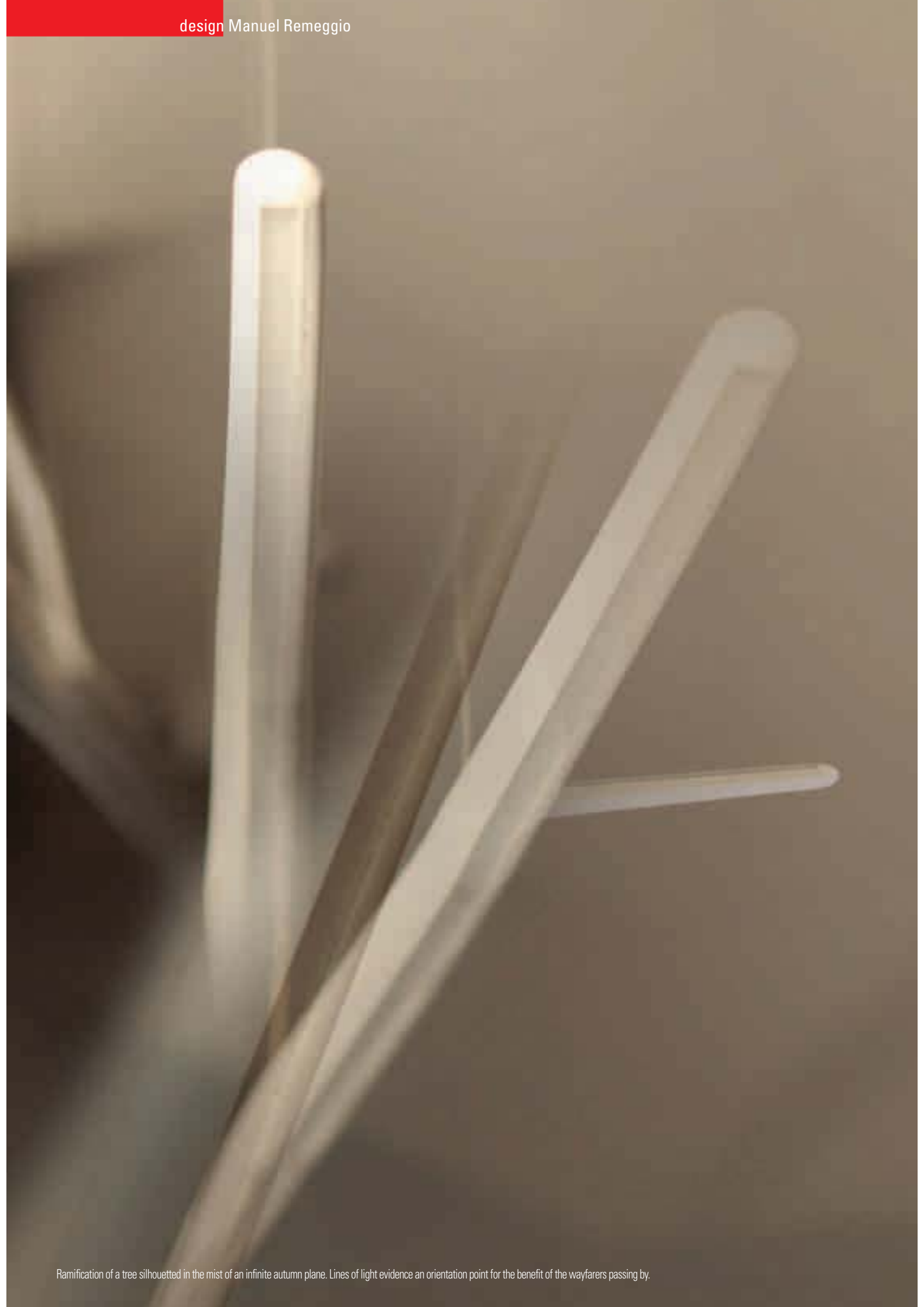



Minimalismo naturale traslato nella materia, Branch arreda elegantemente con una silhouette invidiabile ed illumina con la potenza di LED SMD di ultima generazione.



Natural minimalism transferred into the matter, Branch elegantly furnishes with an enviable silhouette and lights up with the power of cutting-edge SMD LEDs.



Una sospensione in alluminio verniciato bianco oppure lucidato, con un diffusore antiabbagliamento in policarbonato. La luce è a LED.

A suspension luminaire made of white-painted or polished aluminium, with an antiglare polycarbonate diffuser. It features an LED light source.

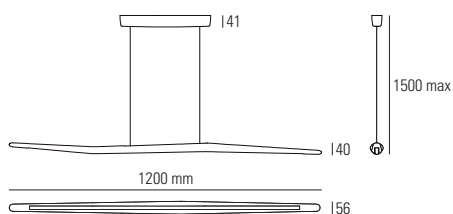

 DOPPIA EMISSIONE / DOUBLE EMISSION

7465 bianco raggrizzante / wrinkled white

7466 alluminio lucidato / polished aluminium

LED 38W 240V
warm white 3000K 2760 lm

CE   IP40  ES



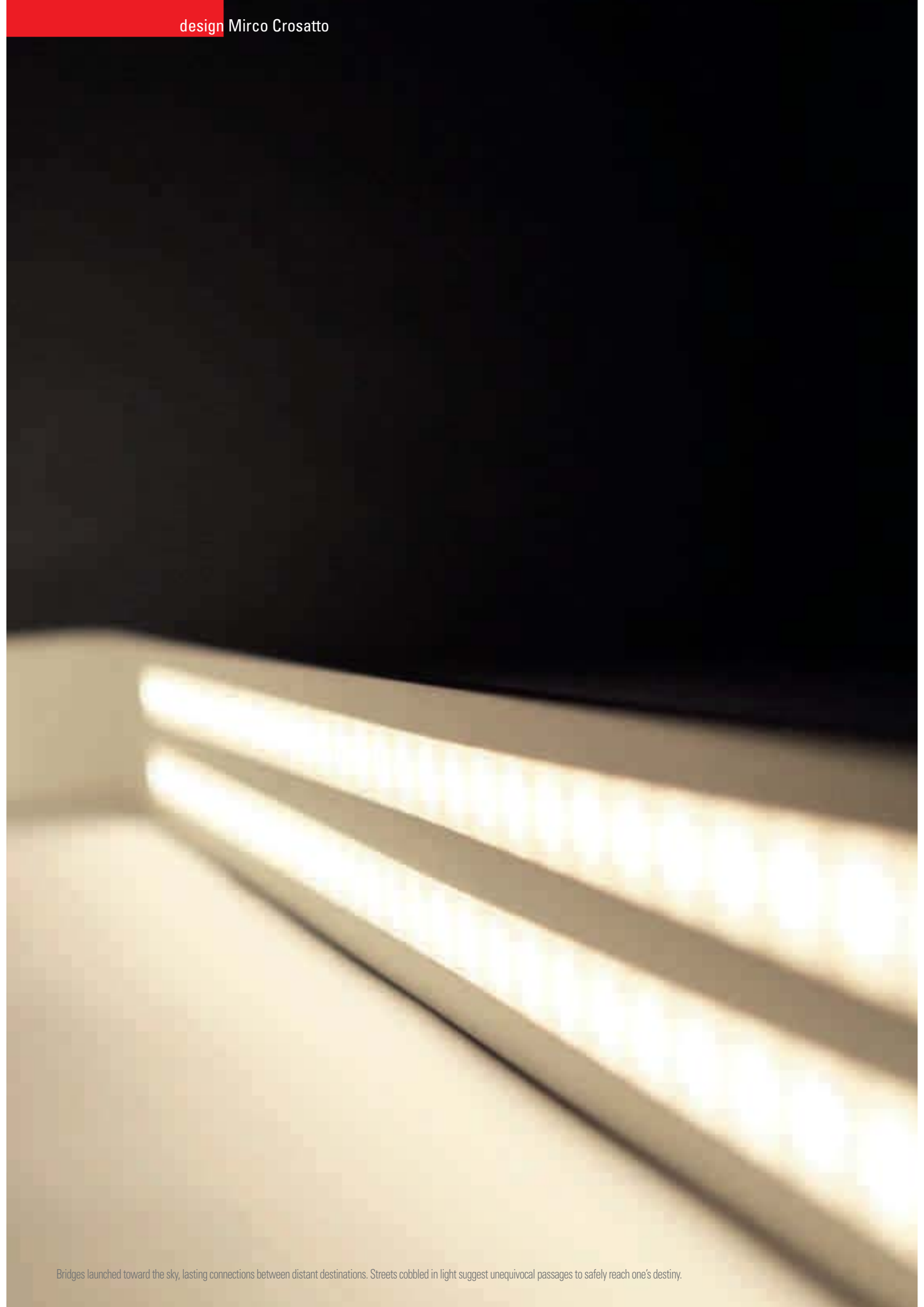

Una famiglia di lampade in alluminio verniciato con effetto raggrinzante, con un diffusore in policarbonato estruso opalino. La luce è a LED.

A family of luminaires made of aluminium painted with a wrinkled effect. The diffuser is made of extruded opaline polycarbonate. It features an LED light.

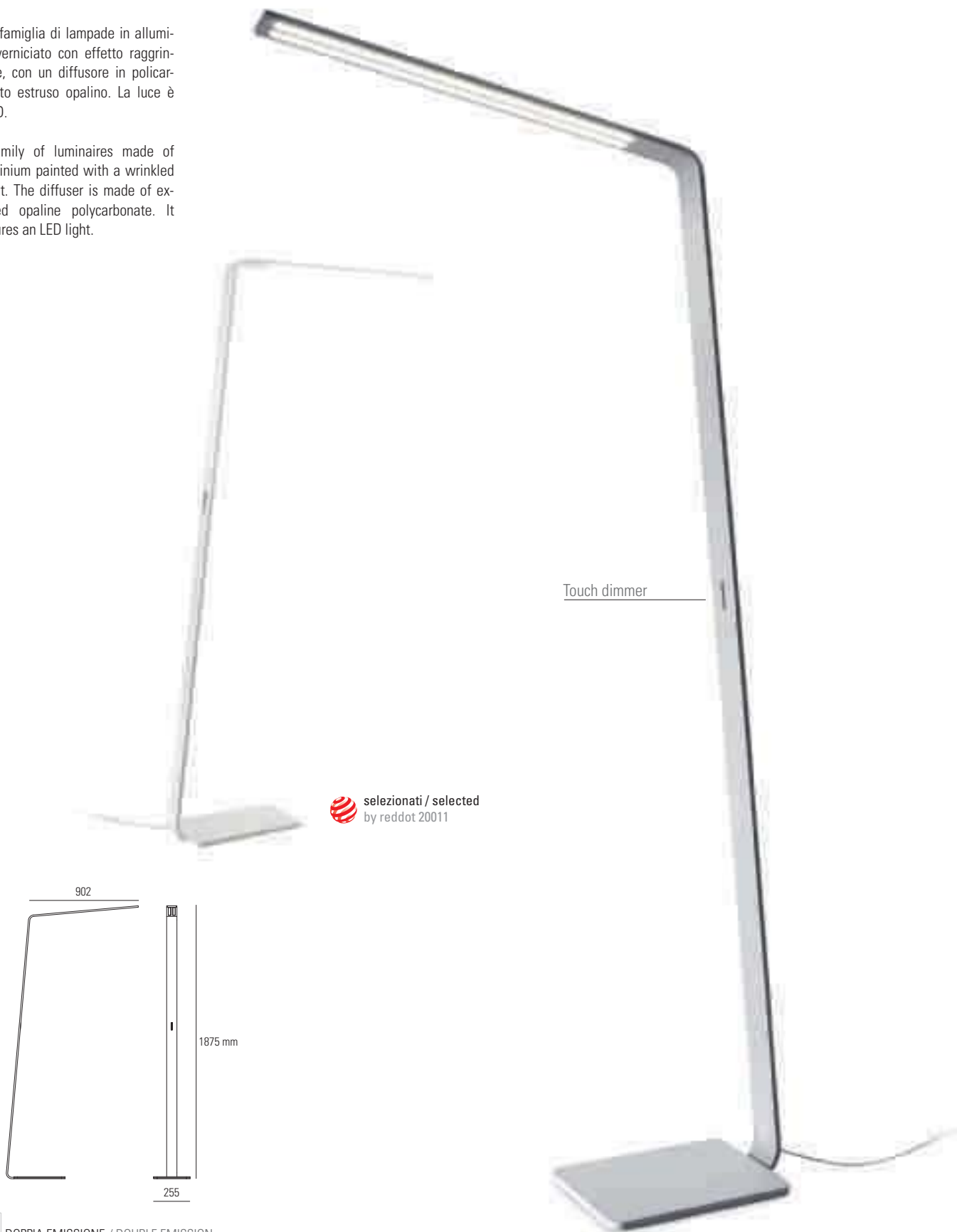

selezionati / selected
by reddot 20011

 DOPPIA EMISSIONE / DOUBLE EMISSION

7100 bianco / white

7102 grigio / gray

LED 22W 240V
warm white 3000K 1620 lm

CE     850° touch dimmer

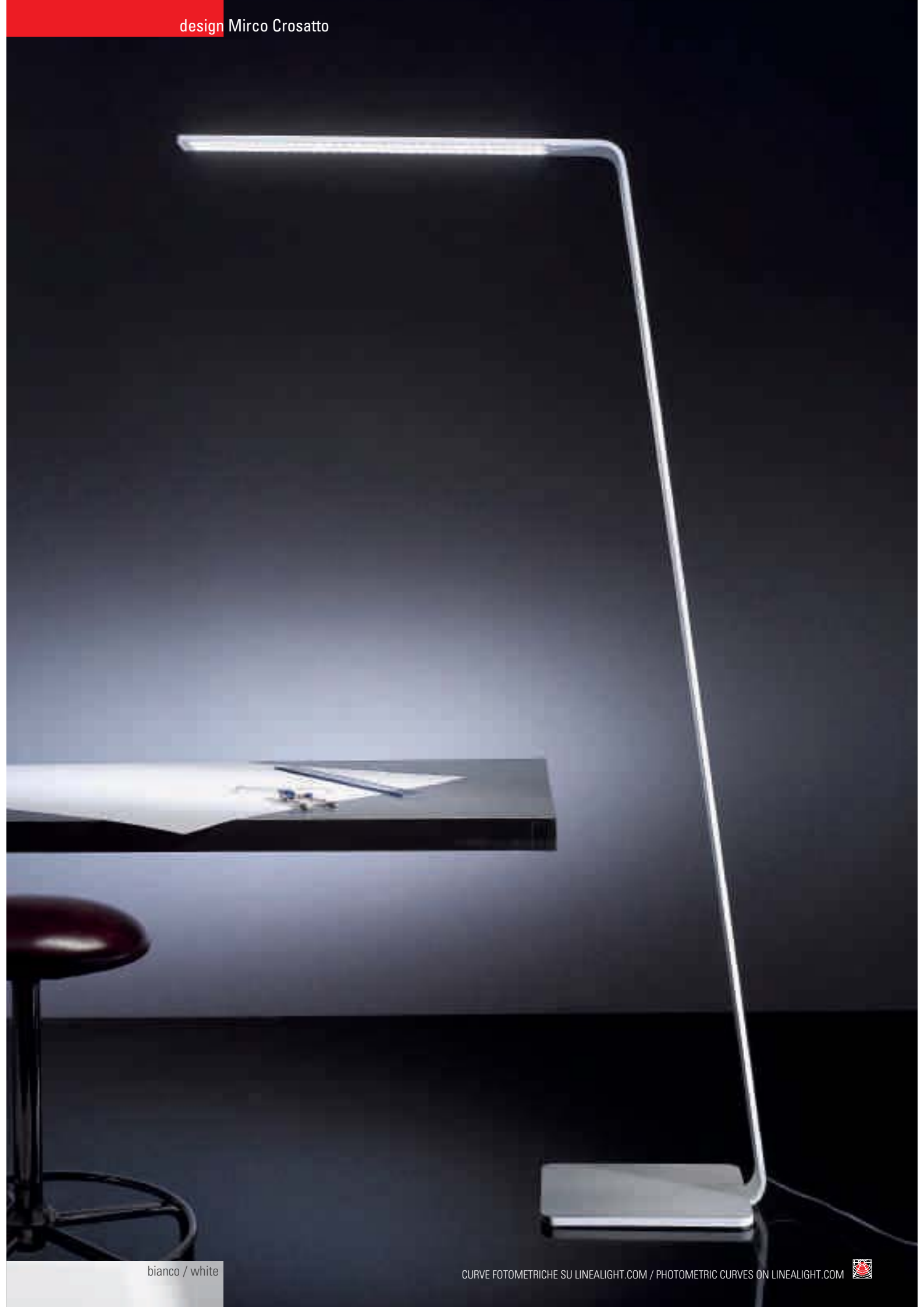

 selezionati / selected
by reddot 20011



Touch dimmer

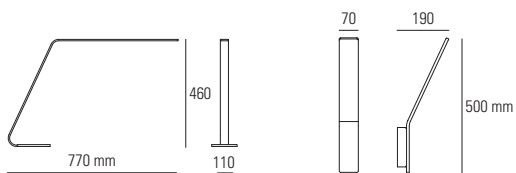

7112 bianco / white
7114 grigio / gray

LED 7W 240V
warm white 3000K 540 lm

CE       touch dimmer



7103 bianco / white
7105 grigio / gray

LED 13W 240V
warm white 3000K 972 lm

CE       IP40     850°





selezionati / selected
by reddot 20011

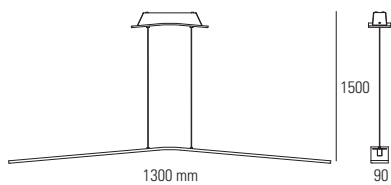

 DOPPIA EMISSIONE / DOUBLE EMISSION

7106 bianco / white

7108 grigio / gray

LED 38W 240V
warm white 3000K 2808 lm

CE  IP40   850°

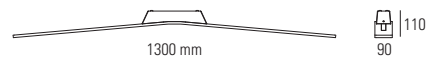

 DOPPIA EMISSIONE / DOUBLE EMISSION

7109 bianco / white

7111 grigio / gray

LED 38W 240V
warm white 3000K 2808 lm

CE  IP40   850°



 selezionati / selected
by redden 20011

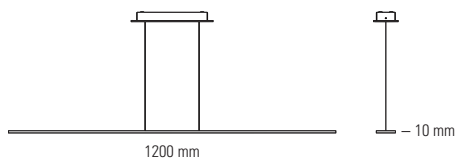

 DOPPIA EMISSIONE / DOUBLE EMISSION

7118 bianco / white

7119 grigio / gray

LED 48W 240V
warm white 3000K 3300 lm

CE     



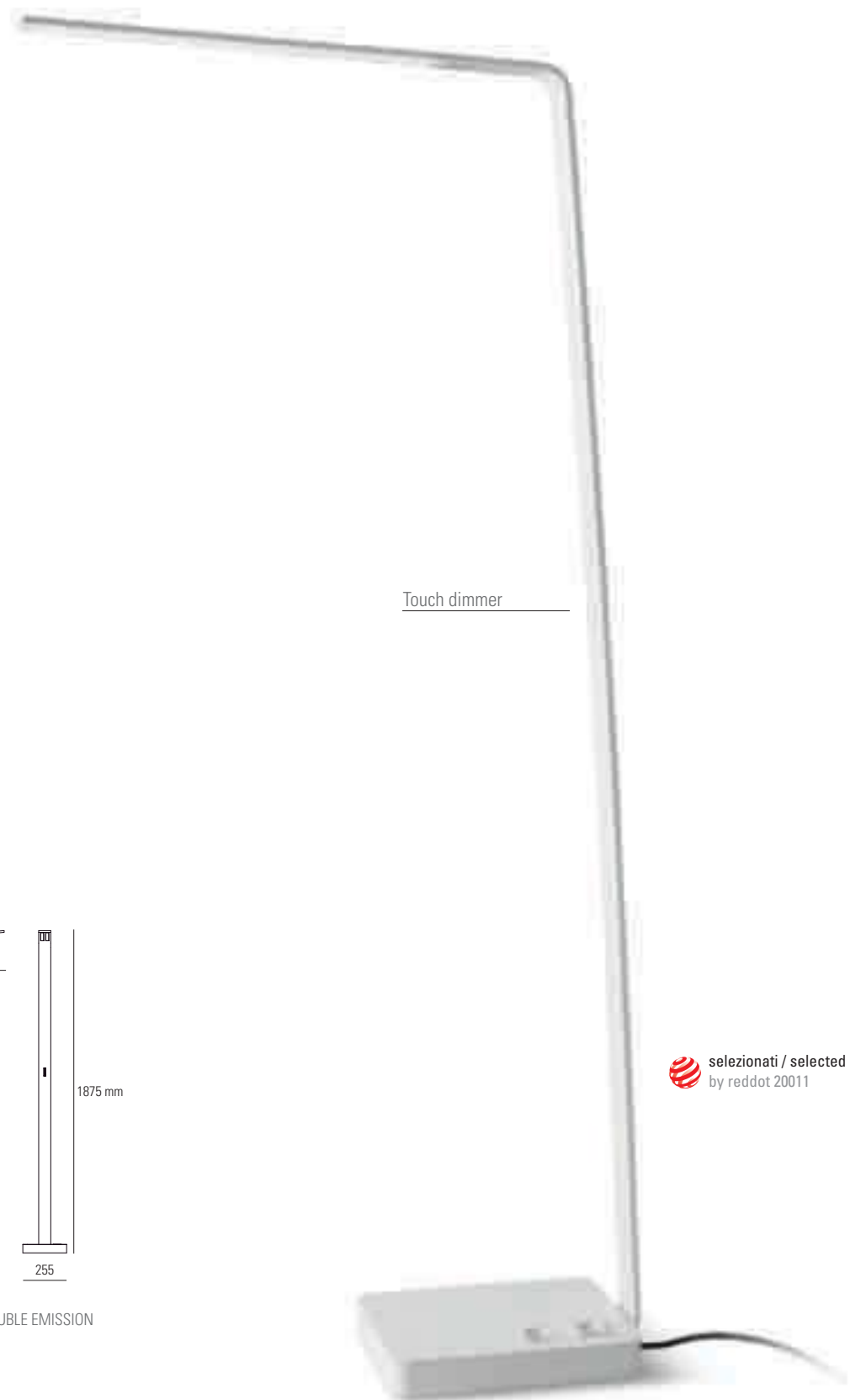

Touch dimmer

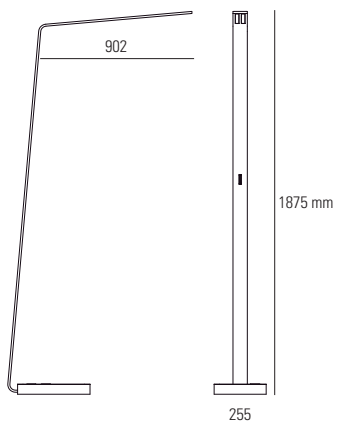

selezionati / selected
by reddot 20011

 DOPPIA EMISSIONE / DOUBLE EMISSION

7116 bianco / white

7117 grigio / gray

LED 39W 240V
warm white 3000K 2640 lm

CE      touch dimmer



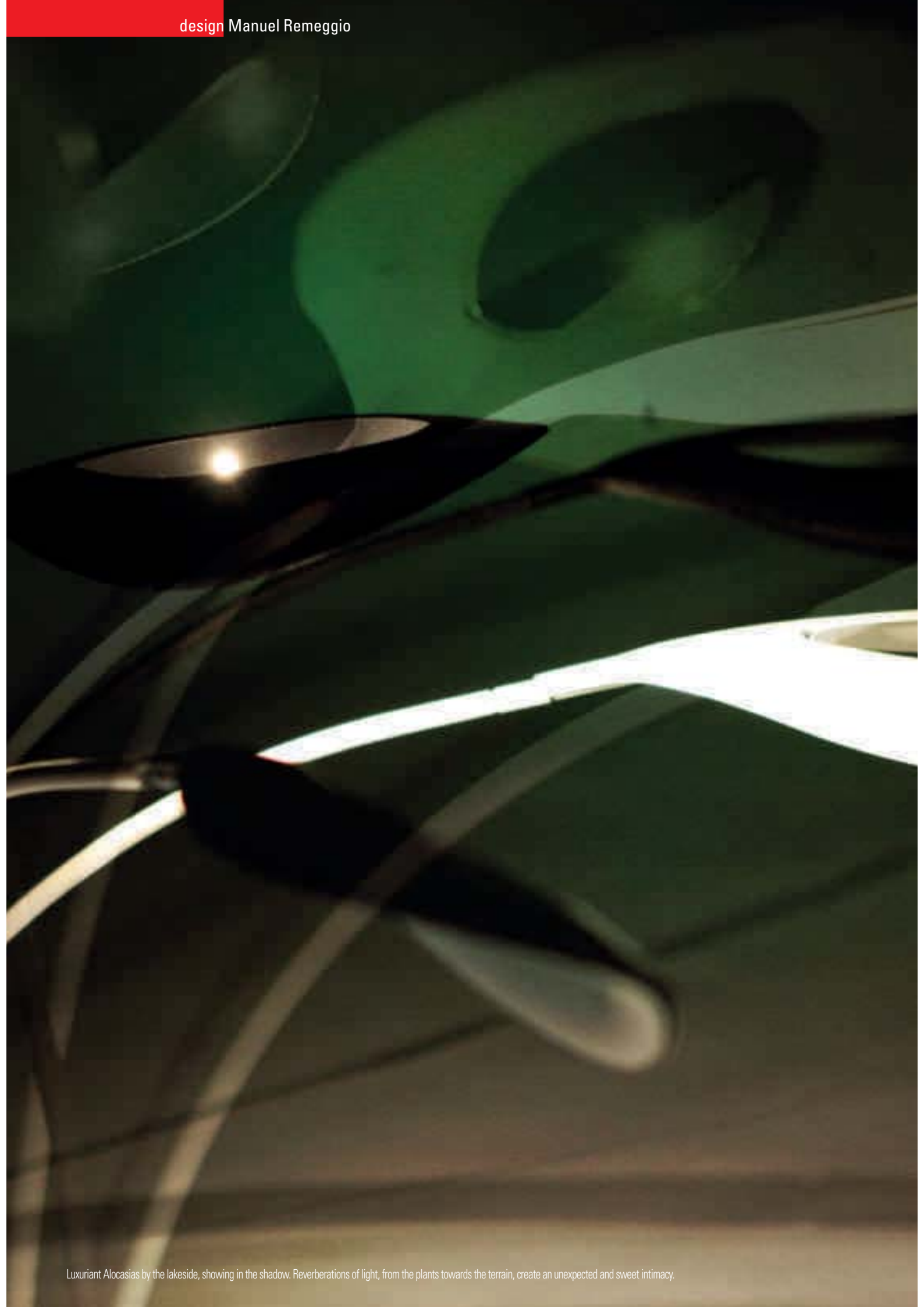

Una famiglia di lampade in metallo e alluminio verniciato con effetto raggrinzante, con copertura della parte illuminante in materiale termoplastico rifinito "carbon-look", oppure in fibra di carbonio. La luce è a LED, con un touch dimmer incluso.

A family of luminaires made of metal and aluminium, painted with a wrinkled effect. The cover of the lighting section is made of thermoplastic with a carbon-look finish, or in carbon fiber. It features an LED light with a touch dimmer.



Touch dimmer

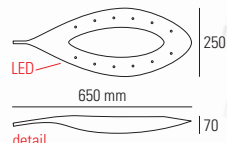

detail

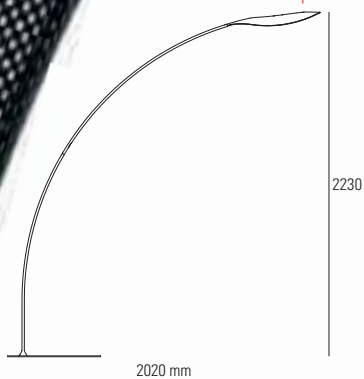

7420 fibra di carbonio / carbon look
7421 bianco / white

LED 24W 240V
warm white 3000K 1166 im



I selezionati / selected
by Idot 2009/2010



selezionati / selected **I.**
by Idot 2009/2010



Touch dimmer

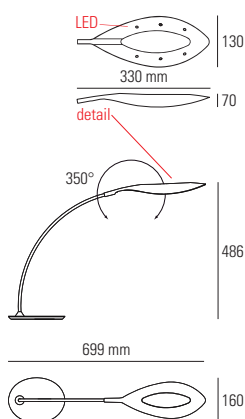

7430 carbon look r
7431 bianco / white

LED 8W 240V
warm white 3000K 392 lm





bianco opaco RAL 9010
matt white RAL 9010



selezionati / selected I.
by Idot 2009/2010

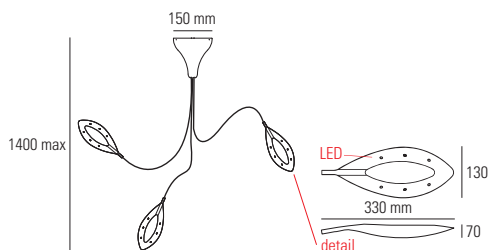

7424 carbon look
7425 bianco / white

LED 24W 240V
warm white 3000K 1176 lm

CE Ⓢ IP40   

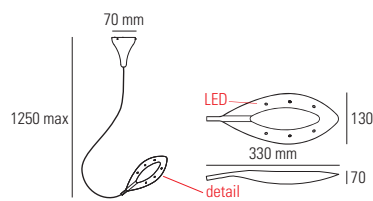

7422 carbon look
7423 bianco / white

LED 12W 240V
warm white 3000K 588lm

CE Ⓢ IP40   





I. selezionati / selected
by Idot 2009/2010

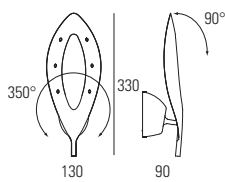

[&]

7428 carbon look r
7429 bianco / white

LED 12W 240V
warm white 3000K 588 lm

CE Ⓢ IP40   850°

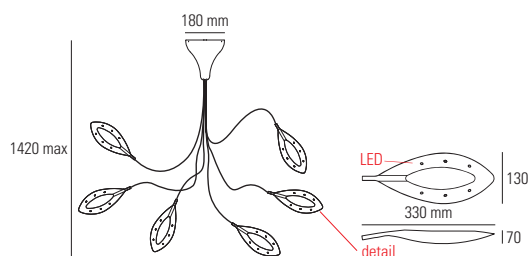

[&]

7426 carbon look
7427 bianco / white

LED 48W 240V
warm white 3000K 2352 lm

CE Ⓢ IP40   850°





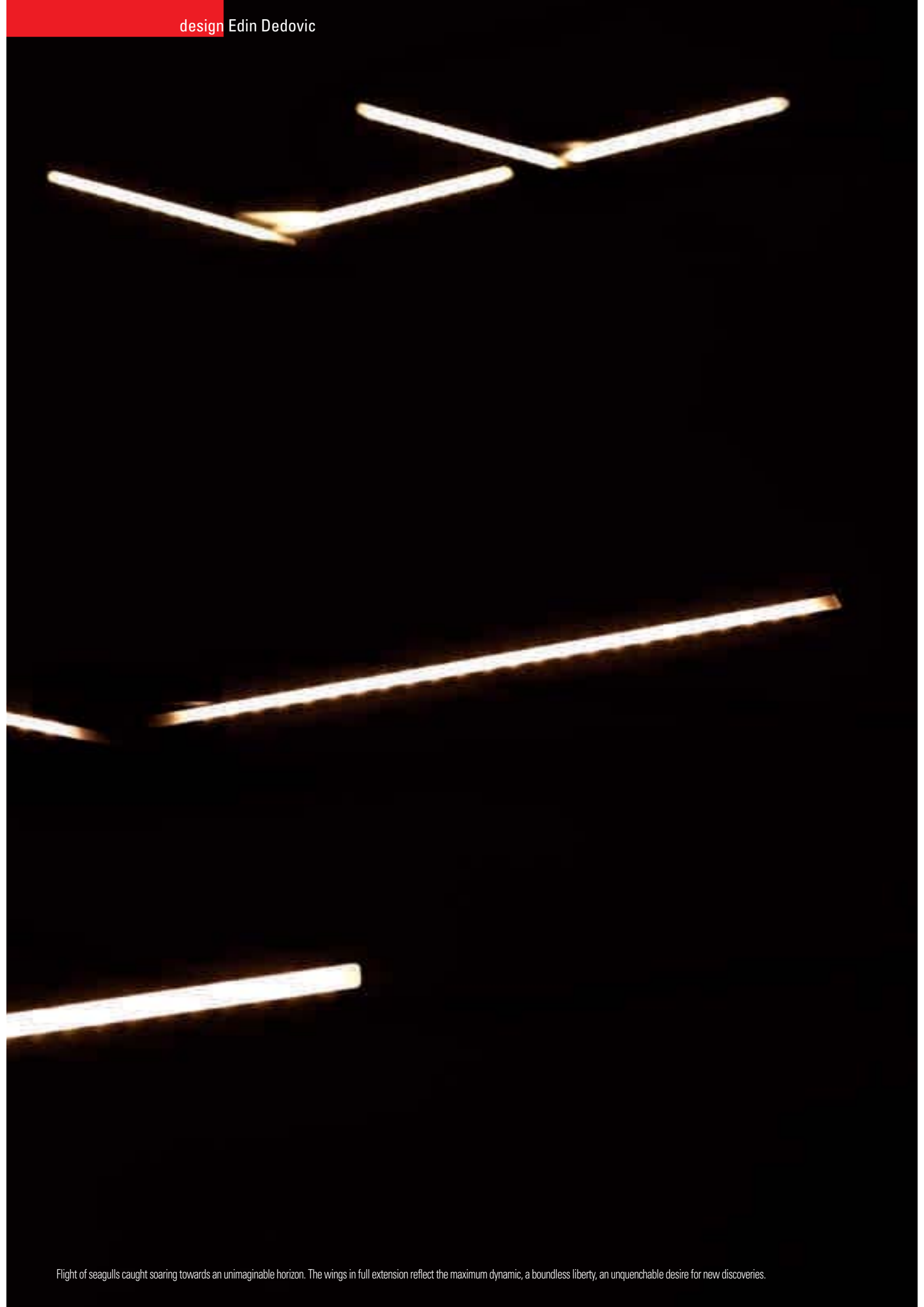



Wings sintetizza semplicità ed eleganza, accoglie e sorprende come una splendente ruota di pavone. La sua luce nasce da LED SMD di ultima generazione e s'apre come un ventaglio sulla parete.



Wings synthesizes simplicity and elegance, welcomes and surprises like a shining peacock train.

Its light originates from cutting-edge SMD LEDs and opens up like a fan on the wall.

Un'appliche in alluminio verniciato, con diffusore antiabbagliamento in policarbonato. La luce è a LED.

A wall luminaire made of painted aluminium, with an antiglare polycarbonate diffuser. It features an LED light source.

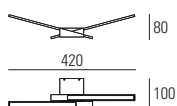

[&]

7411 bianco raggrizzante / wrinkled white
7412 nero raggrizzante / wrinkled black

LED 10W 240V
 warm white 3000K 690 lm

CE Ⓢ IP40 850°

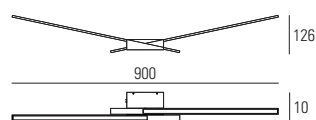

[&]

7414 bianco raggrizzante / wrinkled white
7415 nero raggrizzante / wrinkled black

LED 20W 240V
 warm white 3000K 1380 lm

CE Ⓢ IP40 850°



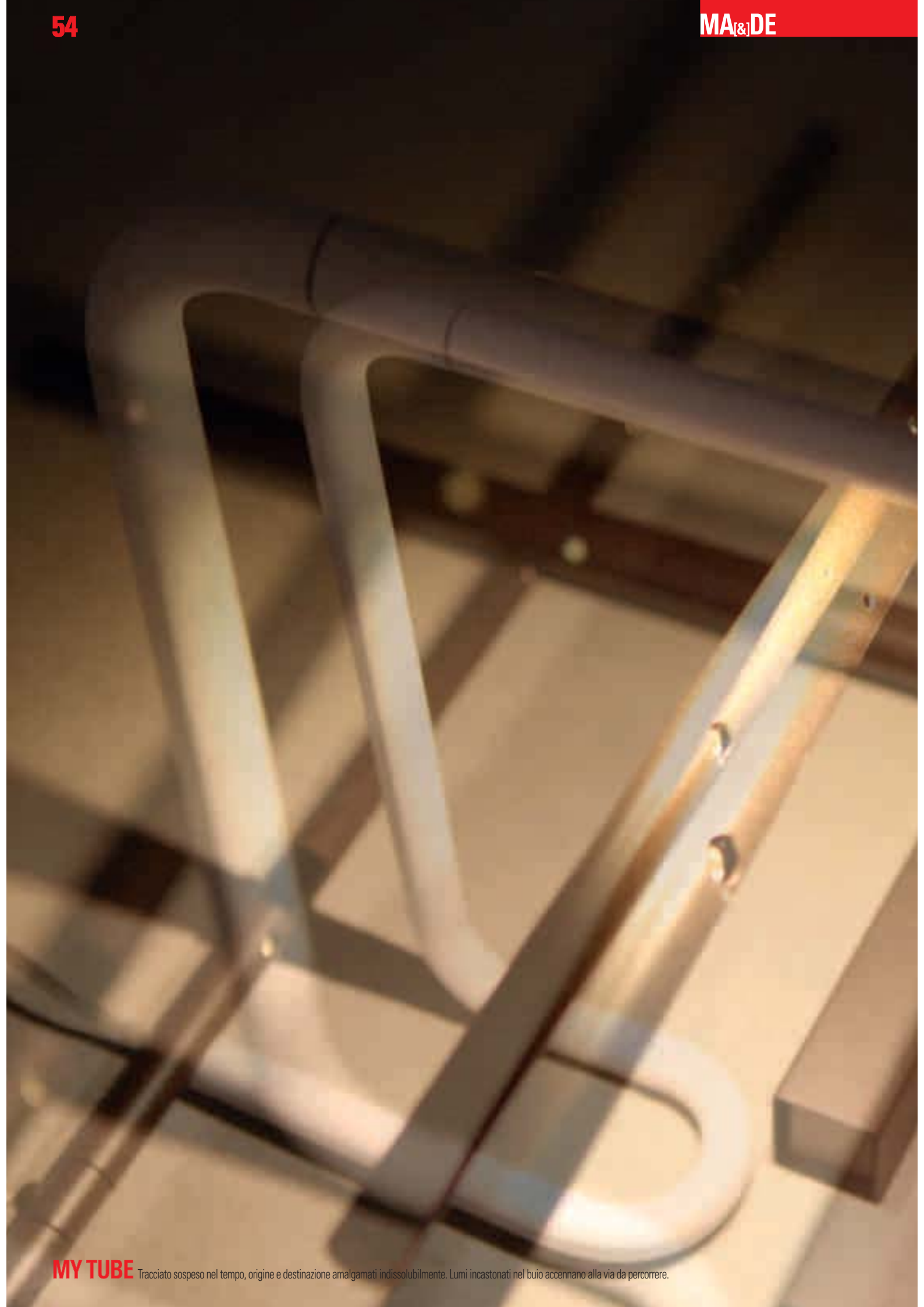

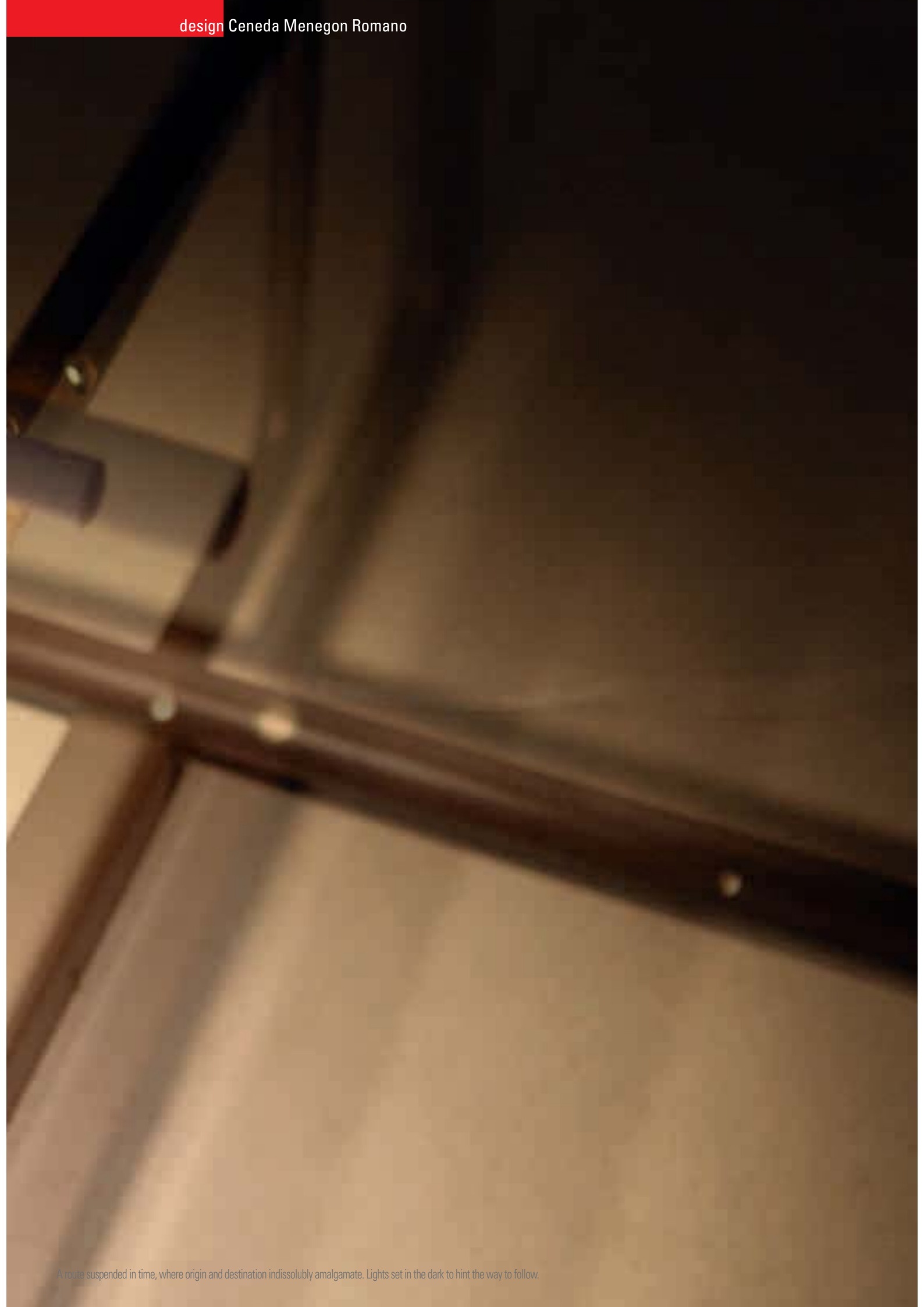

Una famiglia di lampade in alluminio verniciato con effetto raggrinzante. La luce è a LED.

A family of luminaires made of aluminium painted with a wrinkled effect. It features an LED light.

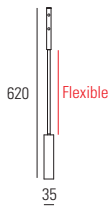
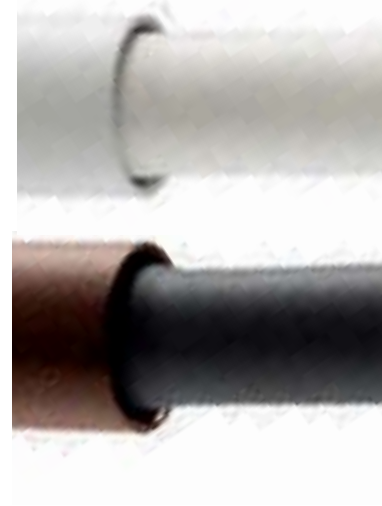

7071 bianco / white

7072 bronzo / bronze

LED 4W 240V
warm white 3000K 196 lm

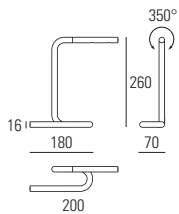

6832 bianco / white

6848 bronzo / bronze

LED 4W 240V
warm white 3000K 196 lm





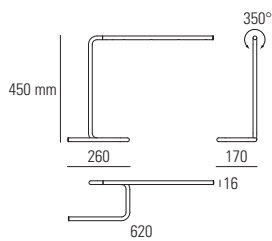

6831 bianco / wrinkled white
6834 bronzo / bronze

LED 4W 240V
 warm white 3000 320 lm

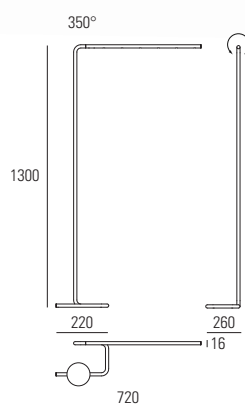

6830 bianco / wrinkled white
6833 bronzo / bronze

LED 6W 240V
 warm white 3000K 480 lm





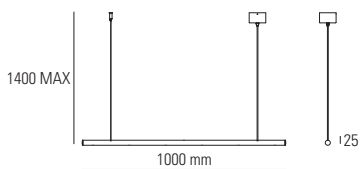
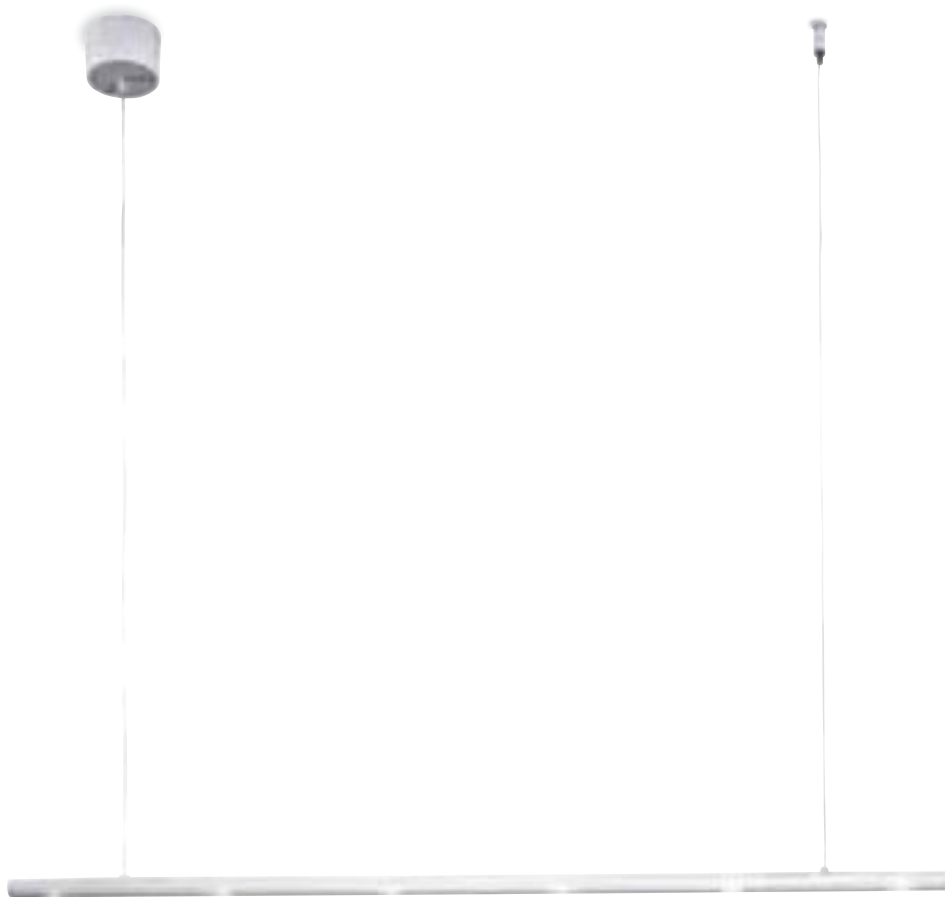

7065 bianco / white
7066 bronzo / bronze

LED 12W 240V
warm white 3000K 588 lm

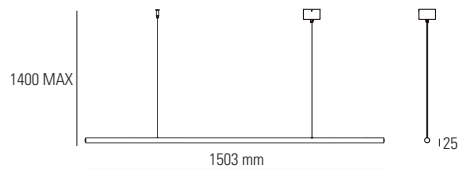

7079 bianco / white
7080 bronzo / bronze

LED 12W 240V
warm white 3000K 960 lm





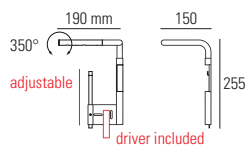

[&]

7075 bianco / white
7076 bronzo / bronze

LED 4W 240V
 warm white 3000K 196 lm

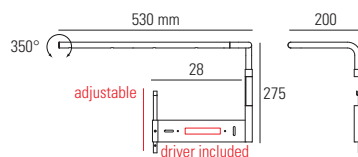

[&]

7077 bianco / white
7078 bronzo / bronze

LED 4W 240V
 warm white 3000K 320 lm





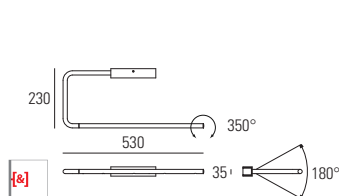

7069 bianco / white
7070 bronzo / bronze

LED 4W 240V
 warm white 3000K 320 lm

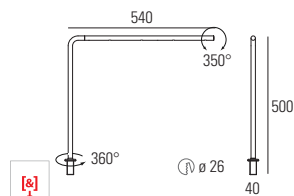

7073 bianco / white
7074 bronzo / bronze

LED 4W 240V
 warm white 3000K 320 lm



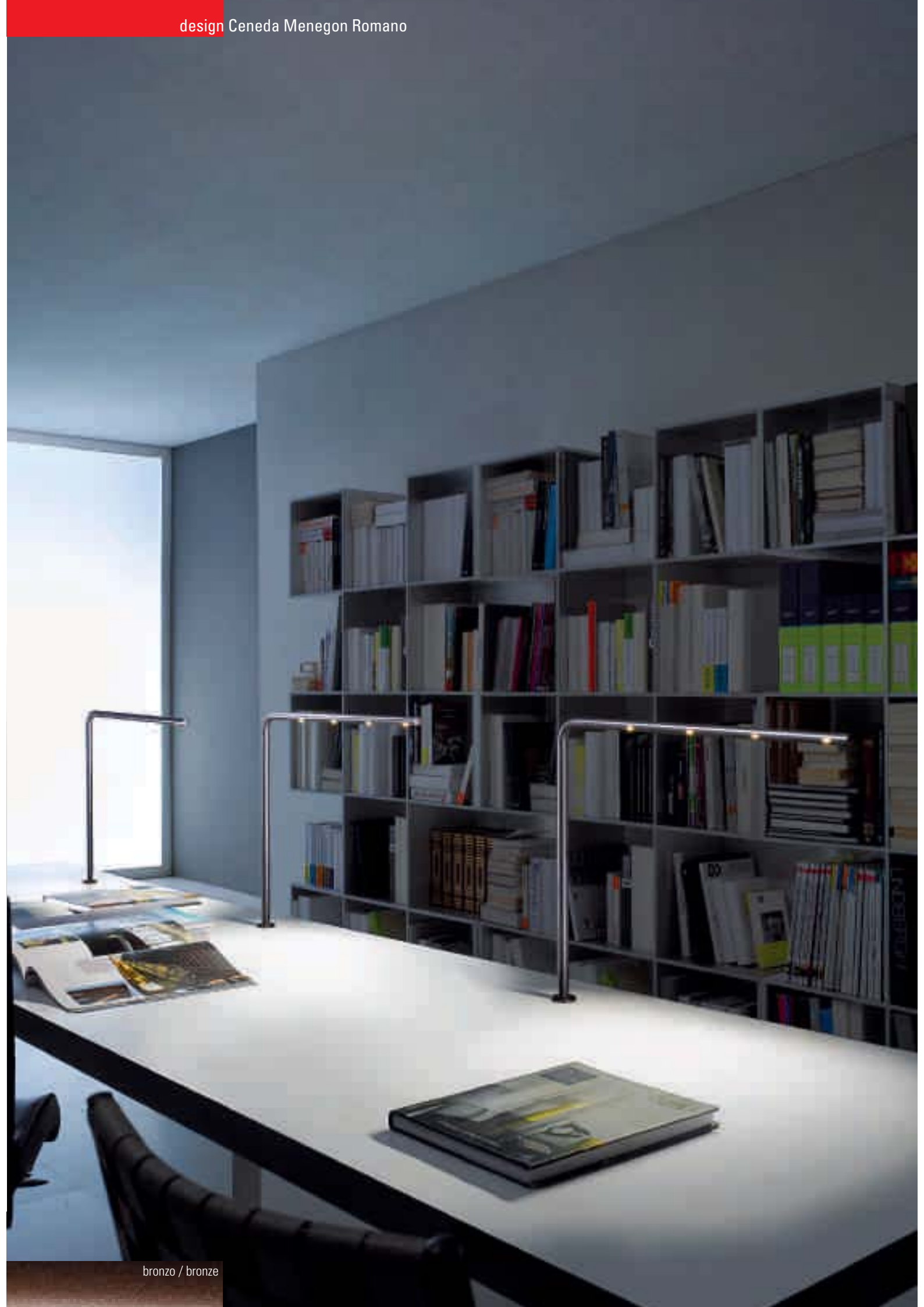





Una lampada da soffitto e parete, in materiale termoplastico verniciato bianco raggrinzante, con un diffusore in policarbonato satinato. La luce è a LED.

A ceiling or wall luminaire made of wrinkled white-painted thermoplastic, with a satin-finished polycarbonate diffuser. It features an LED light source.

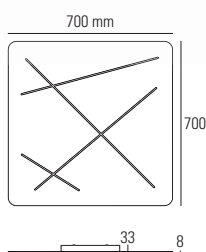

7442 bianco raggrinzante / wrinkled white

LED 73W 240V
warm white 3000K 5016 lm

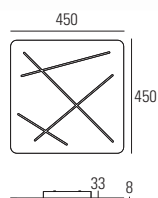

7441 bianco raggrinzante / wrinkled white

LED 46W 240V
warm white 3000K 3168 lm

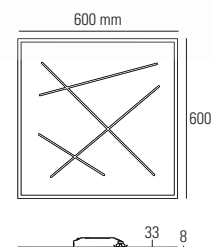

7445 bianco raggrinzante / wrinkled white

LED 58W 240V
warm white 3000K 3960 lm







7443 bianco raggrizzante /
LED 16W 240V
warm white 3000K 1122 lm

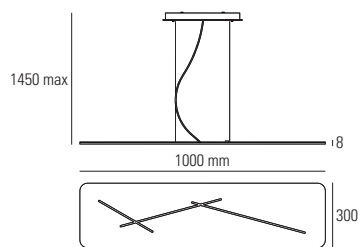

7444 bianco raggrizzante /
LED 39W 240V
warm white 3000K 2640 lm





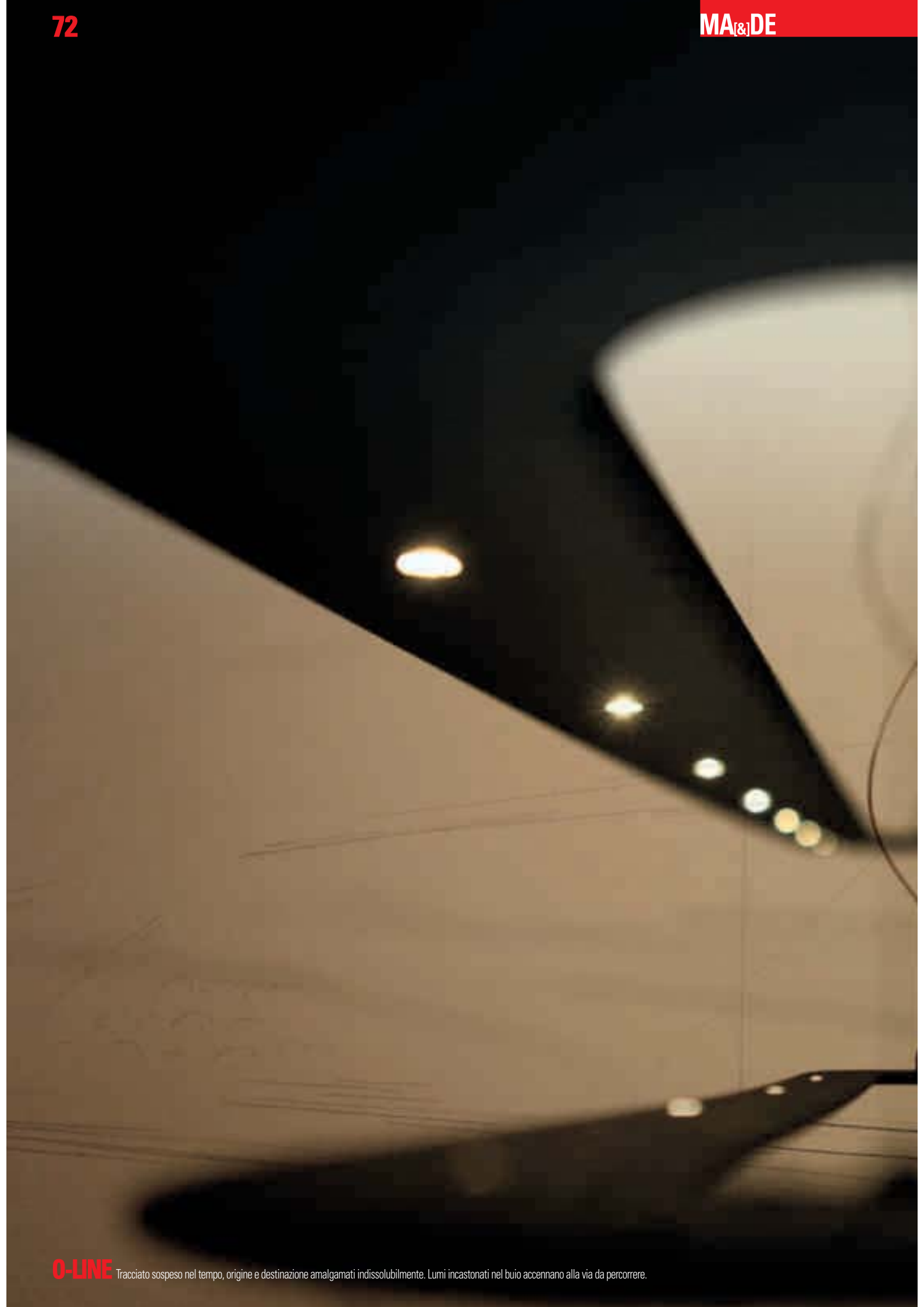

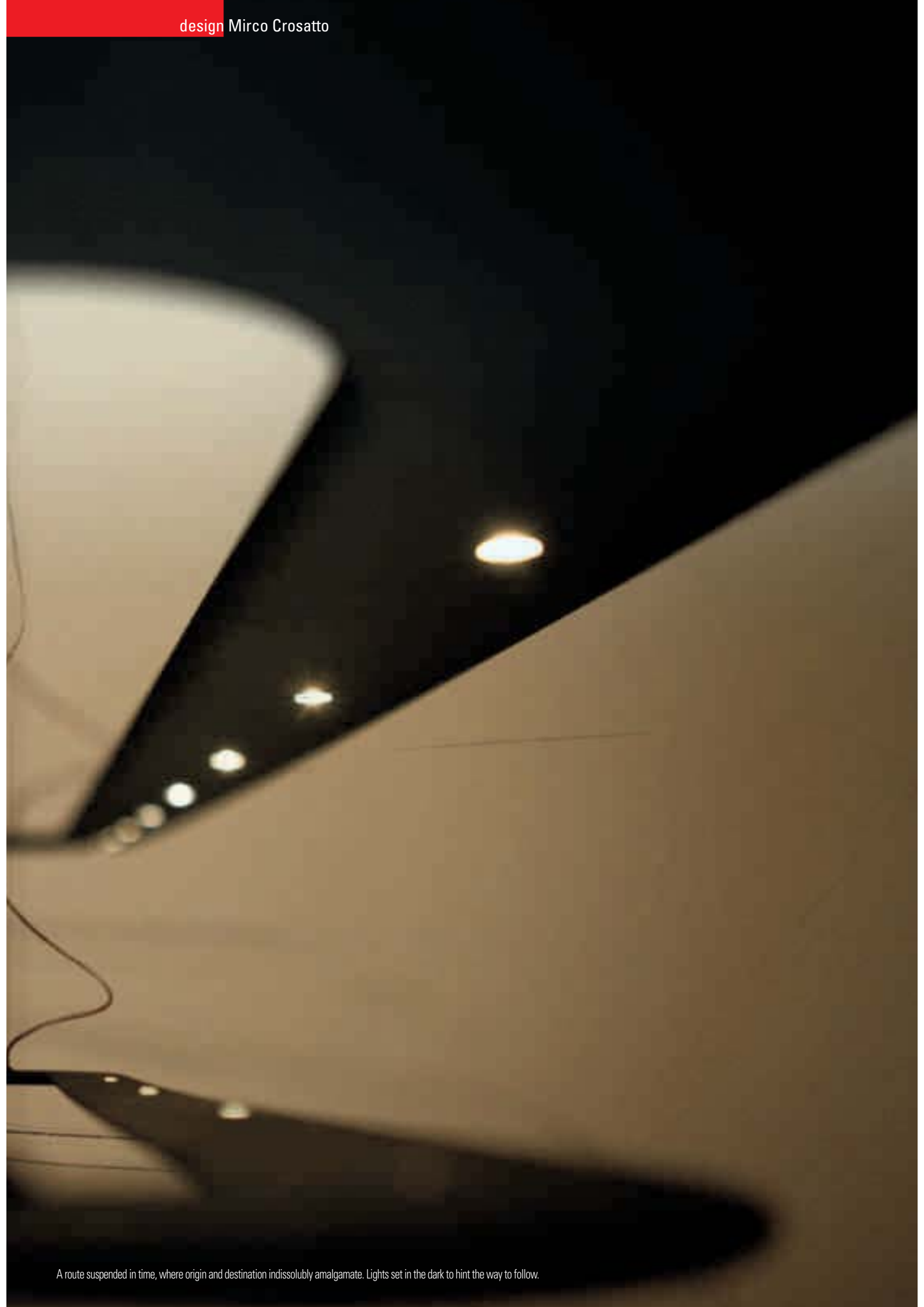

Una sospensione in alluminio verniciato bianco o nero. La luce è LED.

A suspension luminaire, made of white or black coated aluminium. It features a LED light.

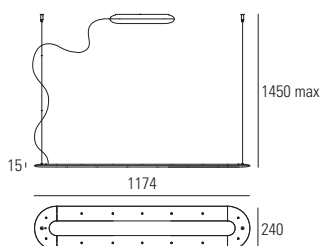

I **[&]** DOPPIA EMISSIONE / DOUBLE EMISSION
DOPPIA ACCENSIONE / DOUBLE SWITCH

6670 bianco / white

6671 nero / black

LED 32W 240V
- 4 sopra/upwards
- 12 sotto/downwards
warm white 3000K 1568 lm

CE 850°

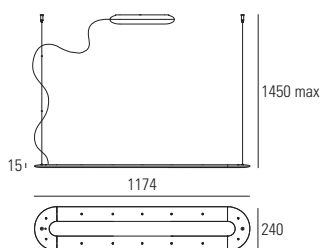

I **[&]** DOPPIA EMISSIONE / DOUBLE EMISSION
DOPPIA ACCENSIONE / DOUBLE SWITCH

solo su richiesta / upon request

6674 bianco / white

6675 nero / black

LED 32W 240V
- 4 sopra/upwards
- 12 sotto/downwards
warm white 3000K 1568 lm

CE 850°

DIMMERABILE / DIMMABLE

design Mirco Crosatto



bianco / white

[CURVE FOTOMETRICHE.SU.LINEALIGHT.COM](http://CURVE.FOTOMETRICHE.SU.LINEALIGHT.COM) / [PHOTOMETRIC CURVES.ON.LINEALIGHT.COM](http://PHOTOMETRIC.CURVES.ON.LINEALIGHT.COM)



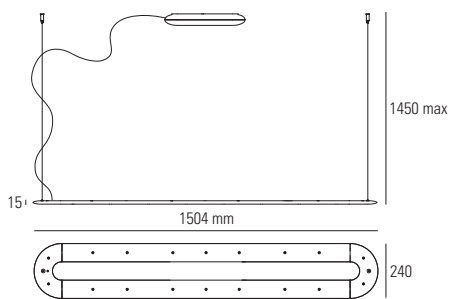

I DOPPIA EMISSIONE / DOUBLE EMISSION
[&] DOPPIA ACCENSIONE / DOUBLE SWITCH

6672 bianco / white

6673 nero / black

LED 33W 240V

- 6 sopra/upwards

- 16 sotto/downwards

warm white 3000K 2156 lm

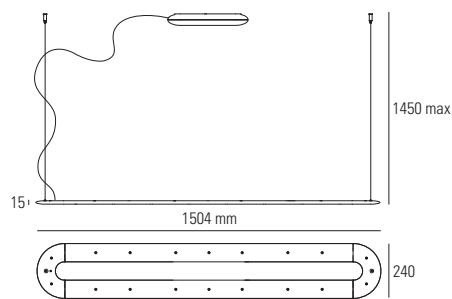

I DOPPIA EMISSIONE / DOUBLE EMISSION
[&] DOPPIA ACCENSIONE / DOUBLE SWITCH

solo su richiesta / upon request

6676 bianco / white

6677 nero / black

LED 44W 240V

- 6 sopra/upwards

- 16 sotto/downwards

warm white 3000K 2156 lm



DIMMERABILE / DIMMABLE





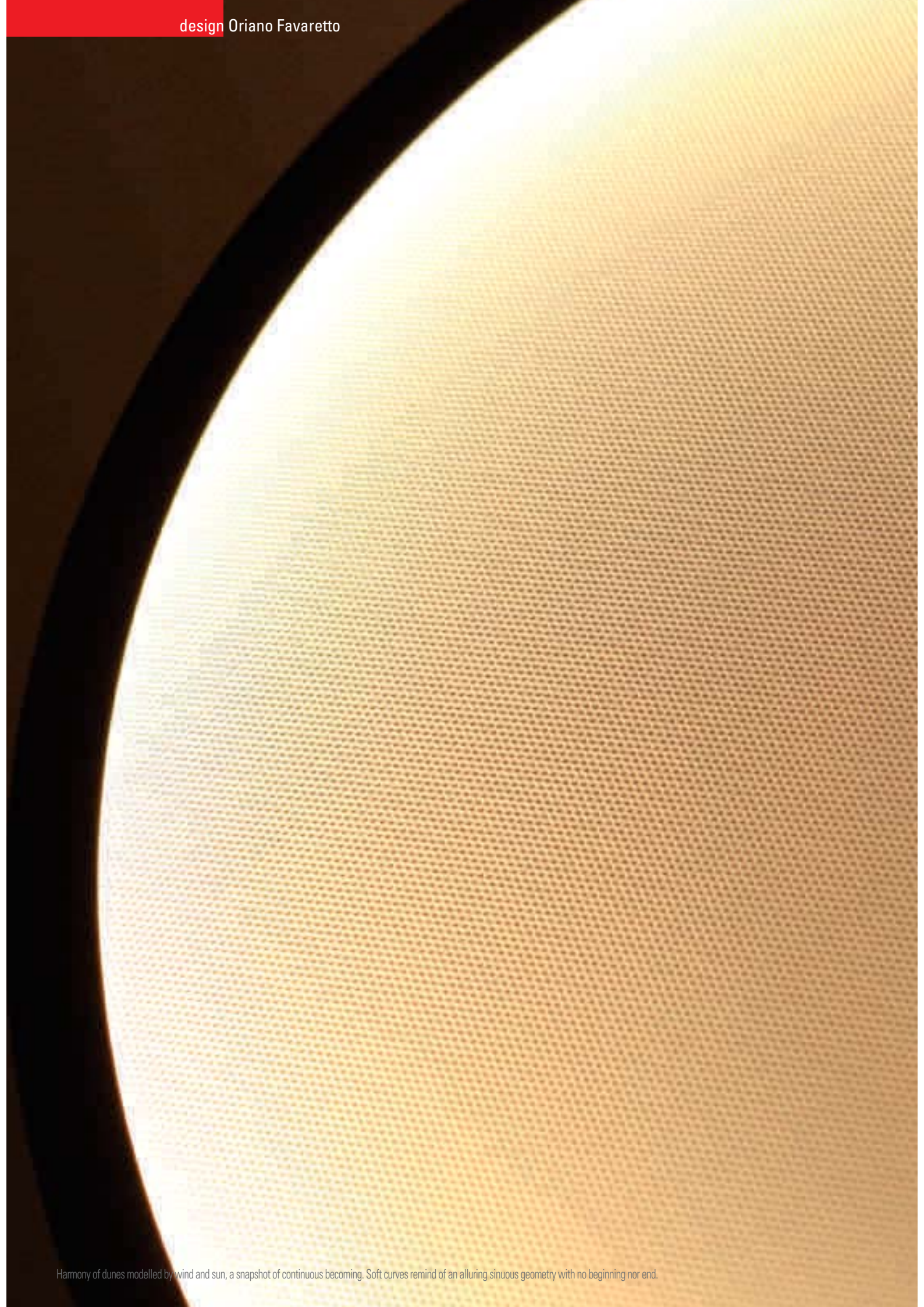

Una sospensione in alluminio verniciato bianco raggrinzante, con un diffusore in PMMA microprismatico. La luce è a LED.

A suspension luminaire made of wrinkled white-painted aluminium, with a microprismatic PMMA diffuser. It features an LED light.

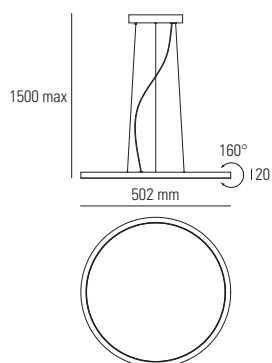

7435 bianco raggrizzante /
LED 30W 240V
warm white 3000K 2232 lm





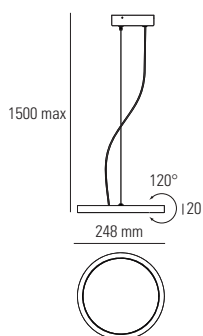

7433 bianco raggrizzante / wrinkled white

LED 15W 240V
warm white 3000K 1080 lm

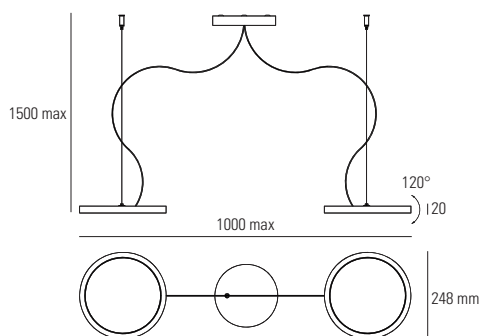

7434 bianco raggrizzante / wrinkled white

LED 30W 240V
warm white 3000K 2160 lm





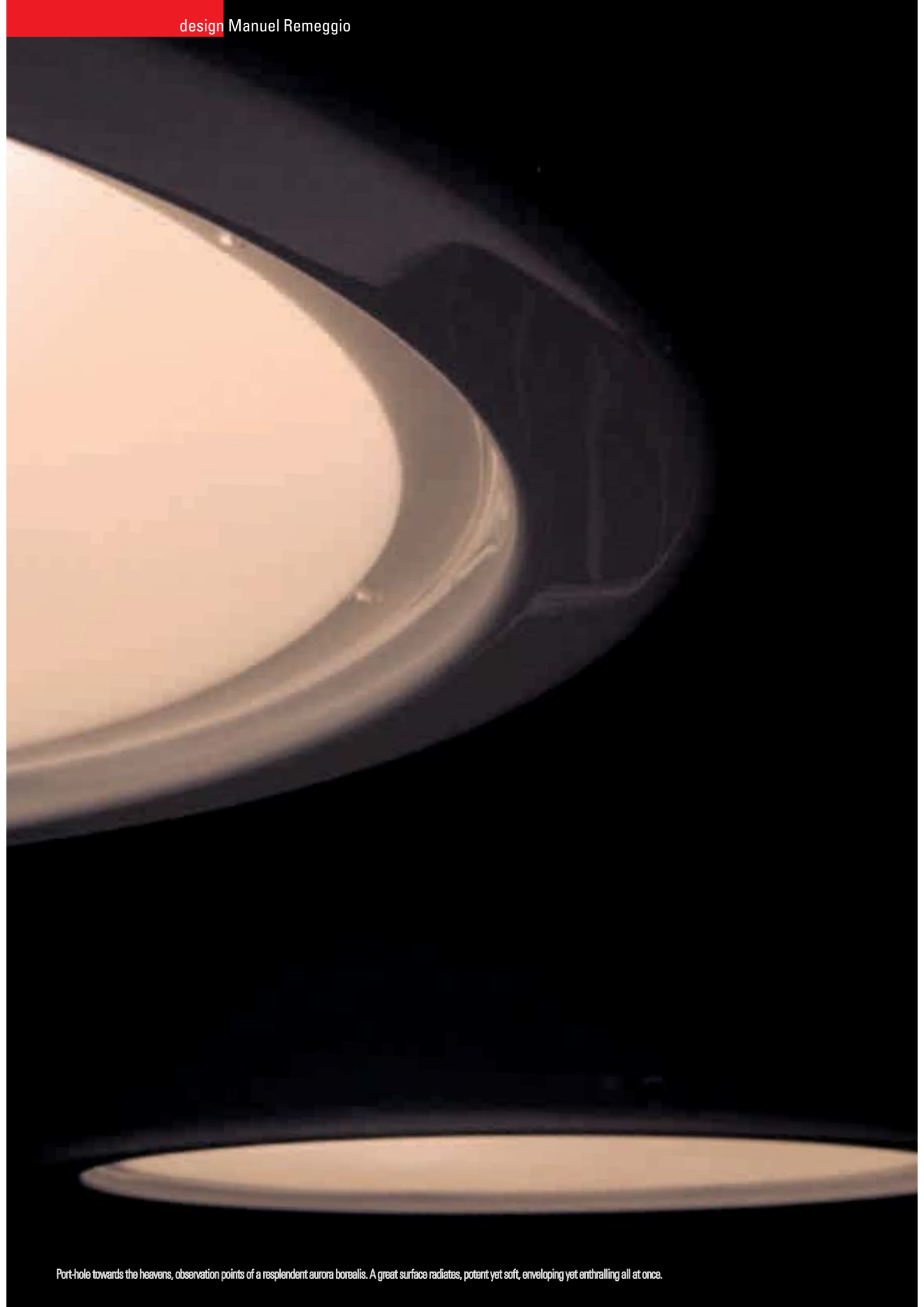

Una lampada da soffitto in polietilene, laccato lucido, con un diffusore prismatico. Illuminazione a LED, oppure grazie all'attacco predisposto per lampadine E27.

A ceiling luminaire made of painted glossy polyethylene, with a prismatic diffuser. It features an LED light, or a light socket for E27 lamps.

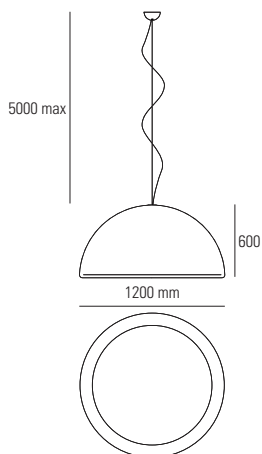

6871 laccato bianco / lacquered white
6872 laccato nero / lacquered black
6873 laccato rosso / lacquered red

E27 5x42W 240V

E27 3x30W 240V

CE Ⓢ IP40

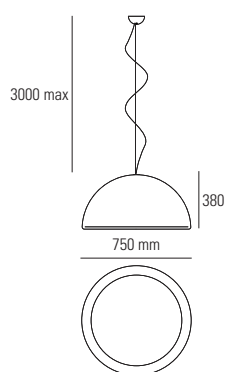

6864 laccato bianco / lacquered white
6865 laccato nero / lacquered black
6866 laccato rosso / lacquered red

E27 3x42W 240V

E27 3x30W 240V

CE Ⓢ IP40

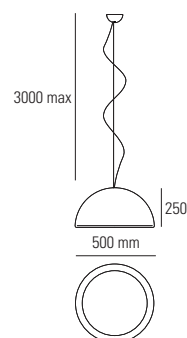

6861 laccato bianco / lacquered white
6862 laccato nero / lacquered black
6863 laccato rosso / lacquered red

E27 1x42W 240V

E27 1x20W 240V

CE Ⓢ IP40



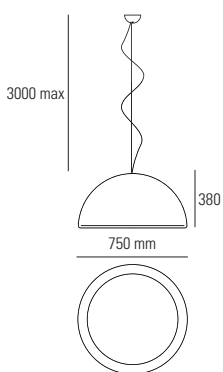

6869 laccato bianco / lacquered white
6868 laccato nero / lacquered black
6867 laccato rosso / lacquered red

LED 2W 240V
 warm white 3000K 1176 lm

CE Ⓢ IP40  

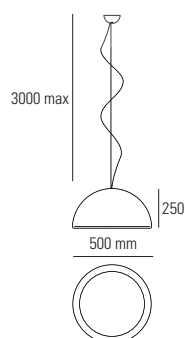

7176 laccato bianco / lacquered white
7177 laccato nero / lacquered black
7178 laccato rosso / lacquered red

LED 2W 240V
 warm white 3000K 686 lm

CE Ⓢ IP40  



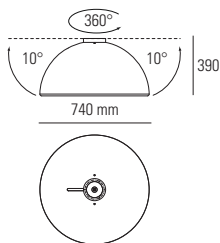

- 7171** laccato bianco / lacquered white
- 7172** laccato nero / lacquered black
- 7173** laccato rosso / lacquered red

LED 2W 240V
warm white 3000K 1176 lm

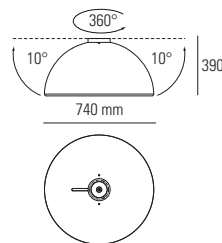

- 7166** laccato bianco / lacquered white
- 7167** laccato nero / lacquered black
- 7168** laccato rosso / lacquered red

E27 3x42W 240V





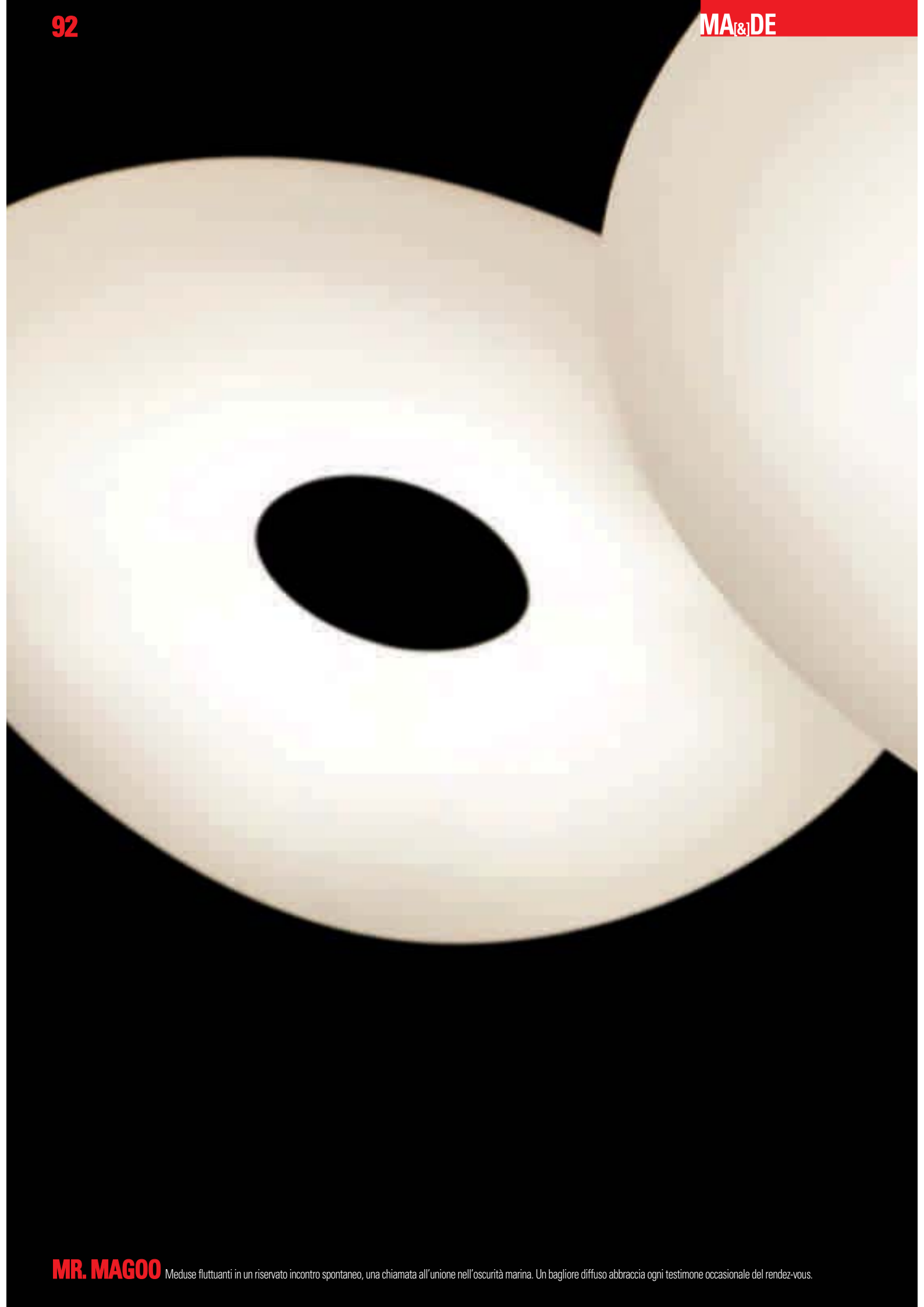

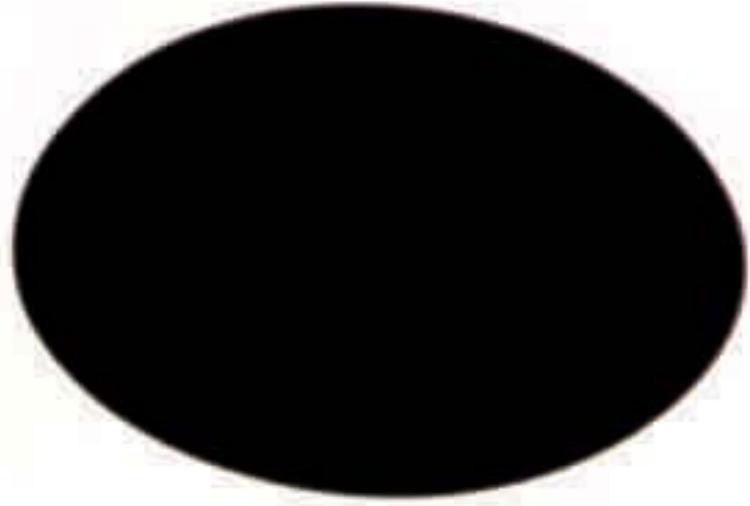

Una lampada da soffitto in polietilene naturale, con montatura in metallo verniciato bianco. La luce è a fluorescenza.

A ceiling luminaire made of natural polyethylene, with a white-coated metal frame. It features a fluorescent light.

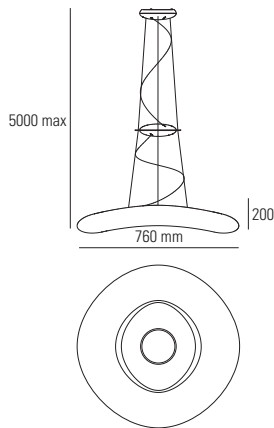

6855 natural / natural

2GX13 1x55W/830 240V

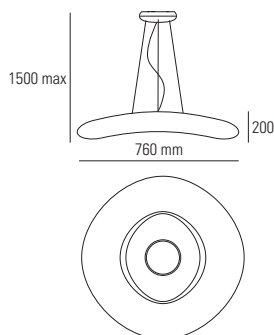

6860 natural / natural

2GX13 1x55W/830 240V

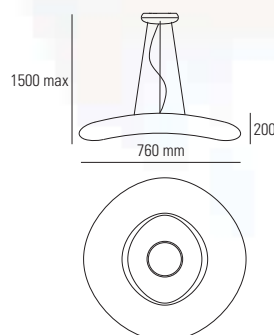

6859 natural / natural

2GX13 1x55W/830 240V



DIMMERABILE / DIMMABLE

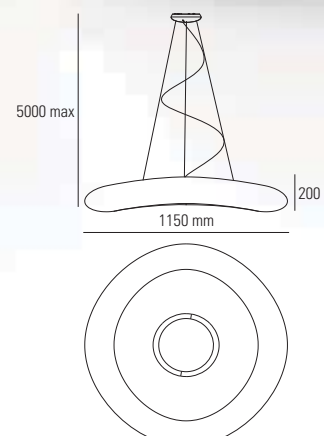

6858 natural / natural

2GX11 4x36W/830 240V





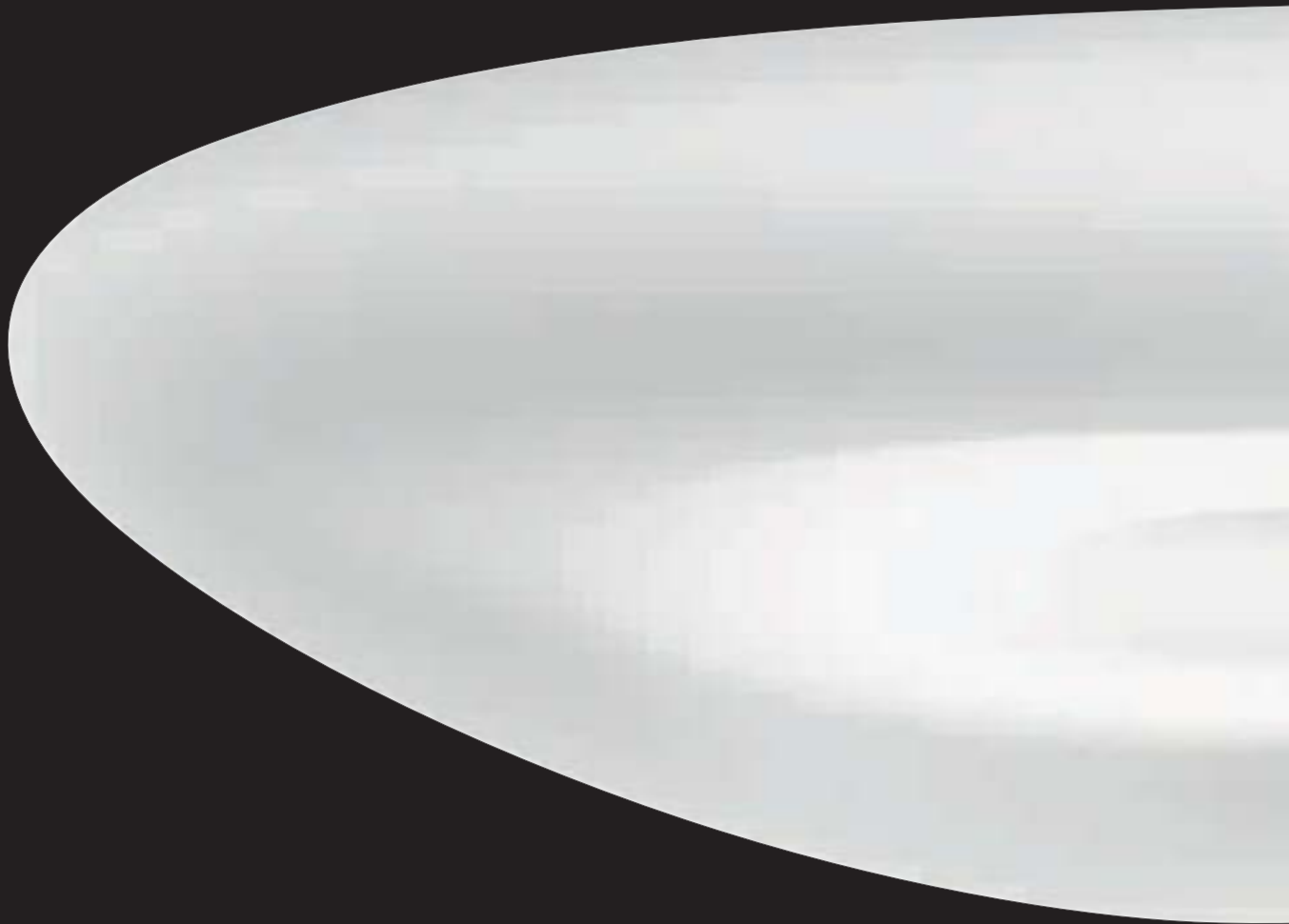

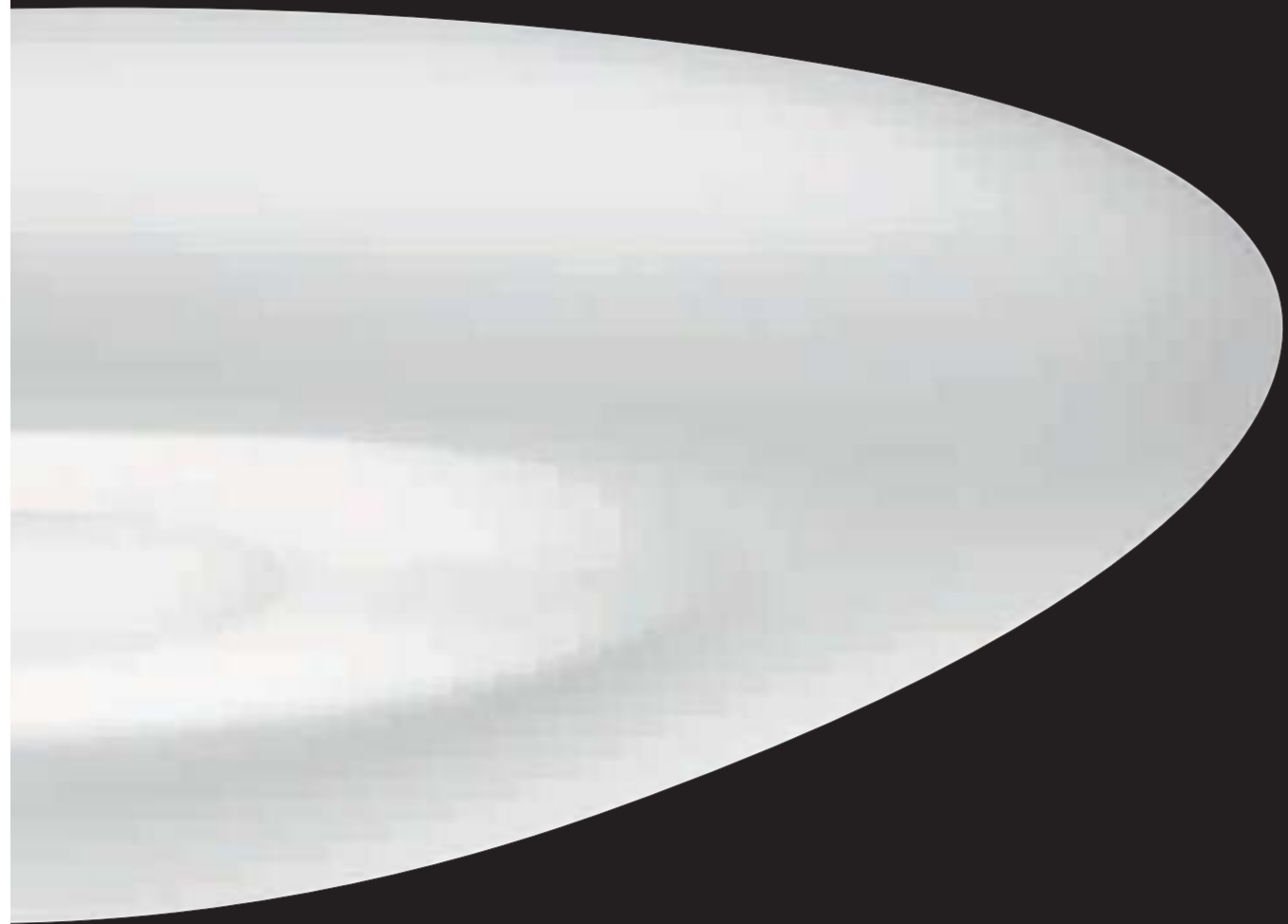

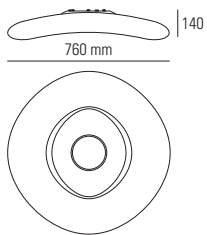

6857 natural / natural
2GX13 55W/830 240V

CE Ⓢ IP40   850°

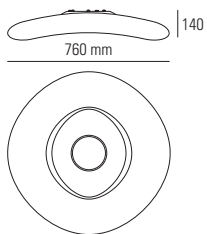

6856 natural / natural
2GX13 55W/830 240V

CE Ⓢ IP40   850° 
DIMMERABILE / DIMMABLE



Una lampada da soffitto in polietilene naturale, con un diffusore conico in PMMA bianco. La luce è a fluorescenza.

A ceiling luminaire made of natural polyethylene with a white, cone-shaped, PMMA diffuser. It features a fluorescent light.

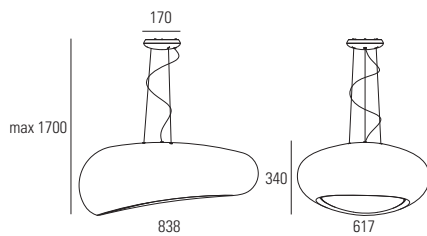

7470 natural bianco / natural white
7473 natural prisma / natural prismatic

E27 3x24W 240V
E27 3x42W 240V

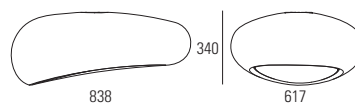

7471 natural bianco / natural white
7472 natural prisma / natural prismatic

E27 3x24W 240V
E27 3x42W 240V







Una lampada da soffitto o parete in vetro soffiato acidato bianco, con una montatura in policarbonato satinato. La luce è a fluorescenza.

A ceiling or wall luminaire made of white acid-etched blown glass, with satin-finished polycarbonate. It features a fluorescent light.

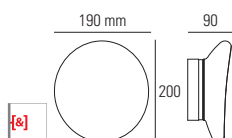

[&]

[&]

6875 vetro opale / opal glass

GX53 1x9W 240V

CE Ⓢ IP44 850°

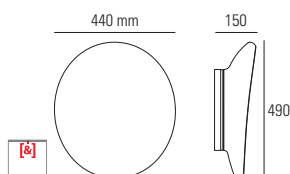

[&]

[&]

6876 vetro opale / opal glass

2GX10 1x36W 240V

CE Ⓢ IP44 850°

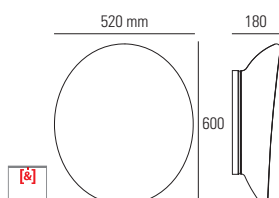

[&]

[&]

6877 vetro opale / opal glass

2GX10 2x36W 240V

CE Ⓢ IP44 850°







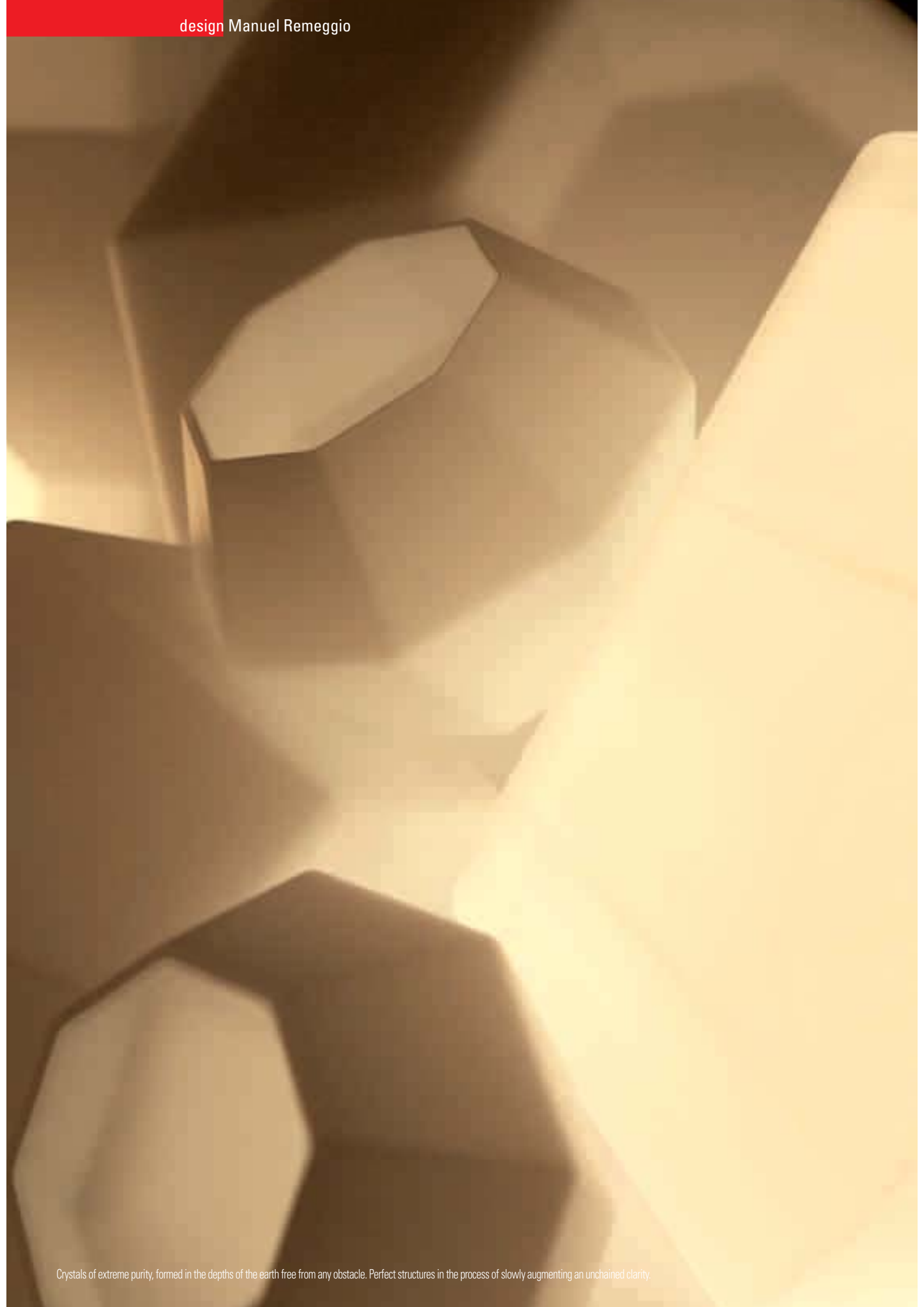

Una lampada da soffitto o parete in vetro soffiato acidato bianco, con una montatura in policarbonato satinato. La luce è a fluorescenza, oppure grazie all'attacco predisposto per lampadine E27.

A ceiling or wall luminaire made of white acid-etched blown glass, with a satin-finished polycarbonate frame. It features a fluorescent light, or a light socket for E27 lamps.

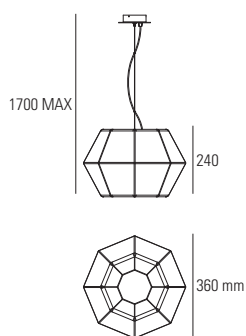
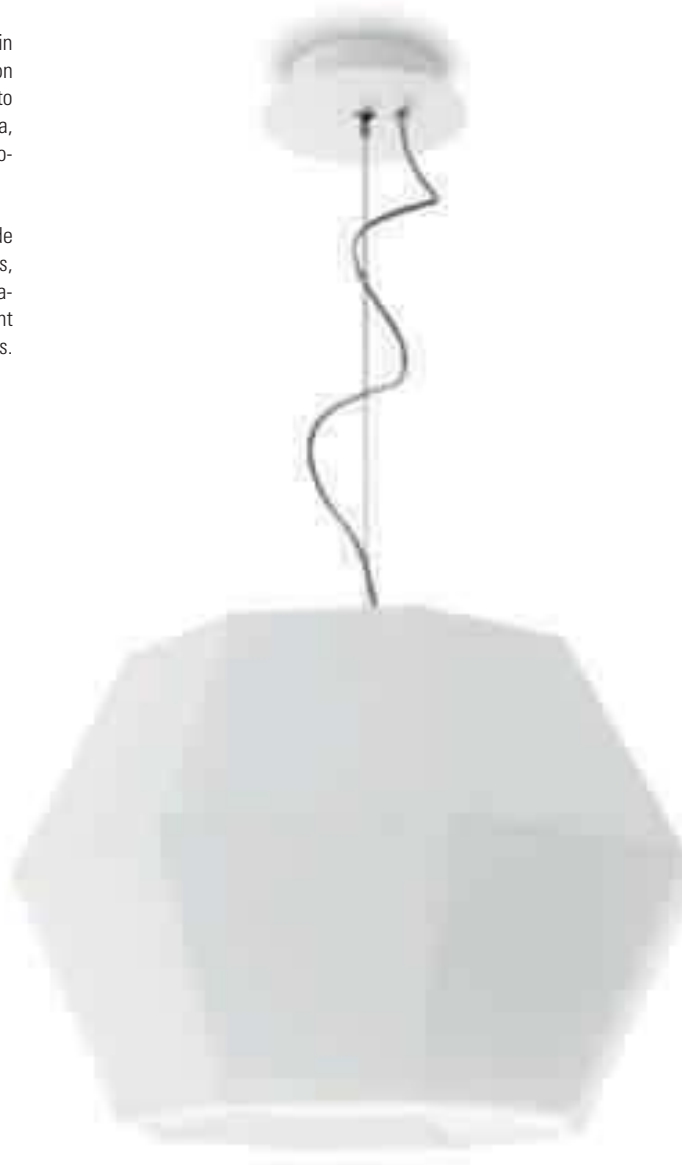

7082 vetro opale/opal glass

E27 1x70W 240V
E27 1x14W 240V

CE Ⓢ Ⓢ Ⓢ Ⓢ Ⓢ 850°

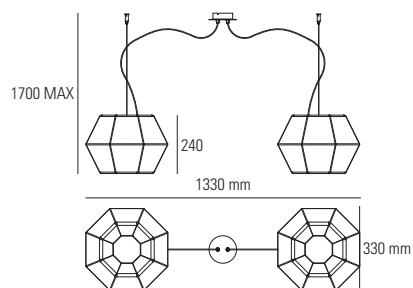

7081 vetro opale/opal glass

E27 2x70W 240V
E27 2x14W 240V

CE Ⓢ Ⓢ Ⓢ Ⓢ Ⓢ 850°





7089 vetro opale / opal glass

E27 1x70W 240V

E27 1x14W 240V

CE       **850°**



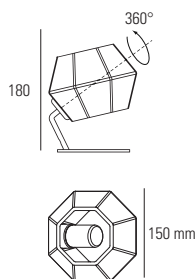

7086 vetro opale / opal glass
G9 1x48W 240V

CE □ ▽ 850°

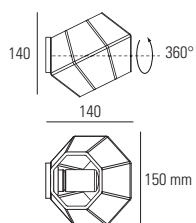

7088 vetro opale / opal glass
G9 1x33W 240V

CE □ ▽ IP44 850°

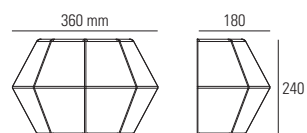

7087 vetro opale / opal glass
E27 2x52W 240V
E27 2x14W 240V

CE ⊕ ▽ 850°





Una sospensione in vinile, con un diffusore antiabbagliamento in policarbonato opalino. La luce è a LED.

A suspension made of vinyl, with an opaline polycarbonate antiglare diffuser. It features a LED light.



La parte superiore dell'articolo è in morbido vinile.

The upper part of the article is made of soft vinyl.

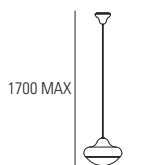

7126 bianco / white

7128 nero / black

LED 7W 240V
warm white 3000K 400 lm

CE



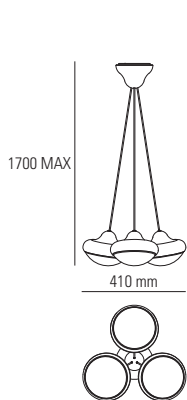

7129 bianco / white
7131 nero / black

LED 21W 240V
warm white 3000K 1200 lm

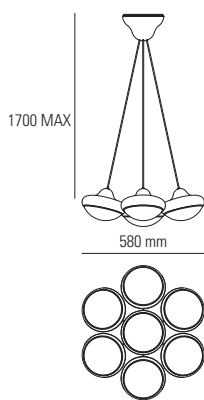

7132 bianco / white
7134 nero / black

LED 49W 240V
warm white 3000K 2800 lm





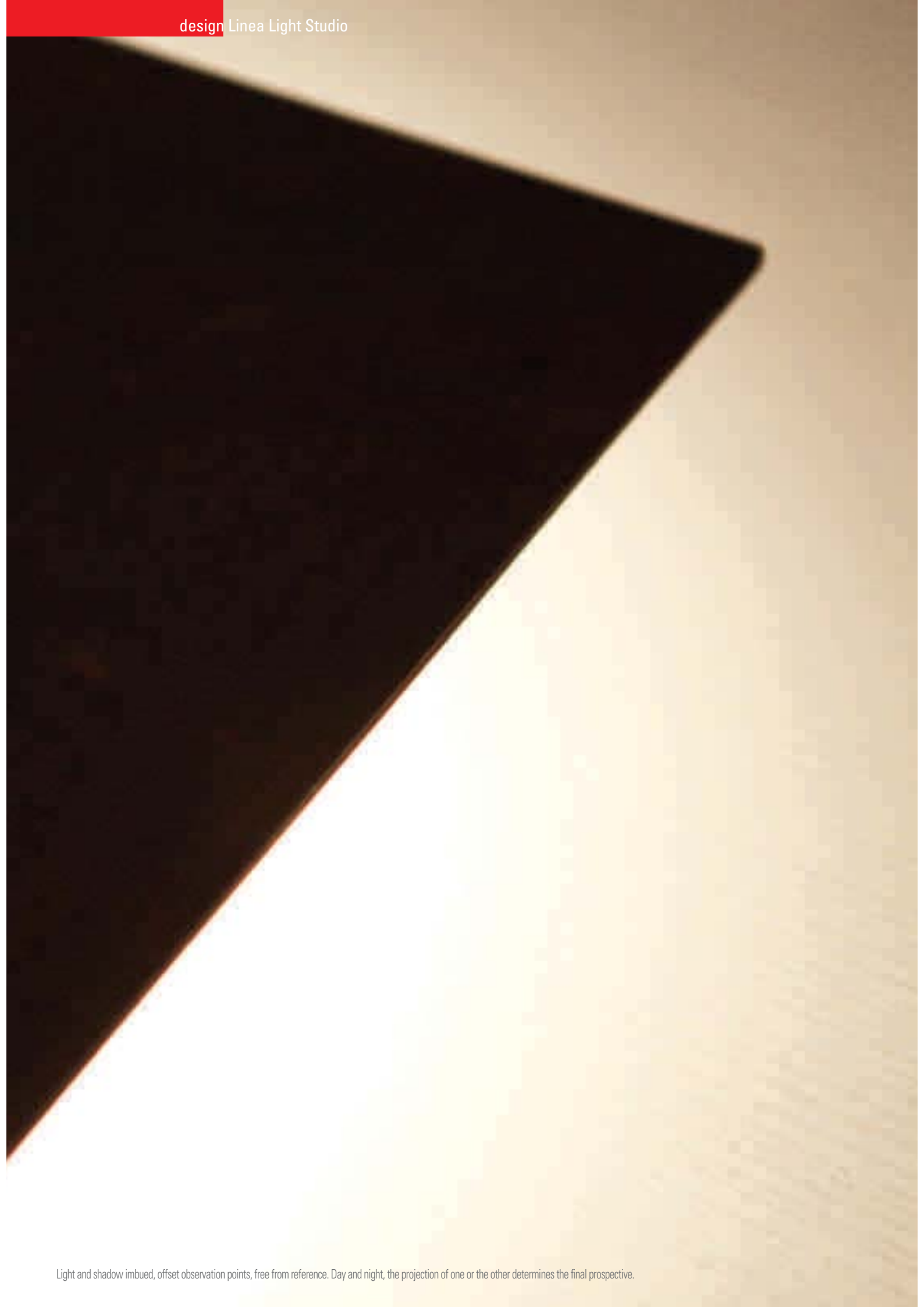

Una famiglia di lampade con diffusore in policarbonato e legno con finiture in bianco, corten o ferro. È presente un attacco predisposto per lampadine a fluorescenza.

A family of luminaires with a wooden frame painted white, corten or iron. The diffuser is made of polycarbonate. It features a light socket for fluorescent lamps.

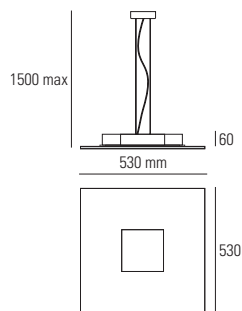

- 6599 bianco / white
- 6600 ferro naturale / natural iron
- 6579 corten / corten

2GX13 1x55W/830 240V





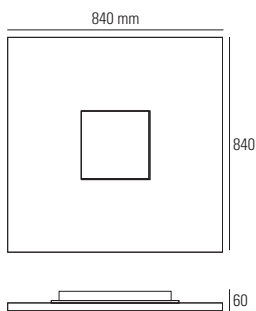

6593 bianco / white
6594 ferro naturale / natural iron
6577 corten / corten

2G11 4x24W/830 240V
 +2GX13 1x22W/830 240V

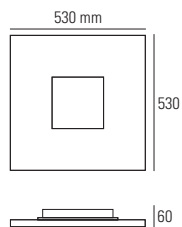

6590 bianco / white
6591 ferro naturale / natural iron
6576 corten / corten

2GX13 1x55W/830 240V

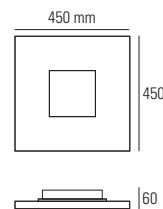

6587 bianco / white
6588 ferro naturale / natural iron
6575 corten / corten

2GX13 1x22W/830 240V

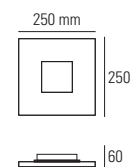

6626 bianco / white
6627 ferro naturale / natural iron
6624 corten / corten

G9 1x48W 240V





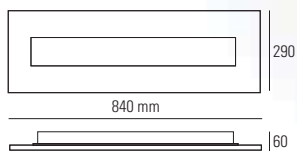

- 6596 bianco / white
- 6597 ferro naturale / natural iron
- 6578 corten / corten

G5 2x39W/830 240V







M

etto

al
Primo
Starnuto.....



CORRIERE

Radio-televisione **TELEFUNK** La nuova tv

Frollati

che richiede un
piego

Il suo partner ha chiesto
che richieda un
piego

La nuova tv
La nuova tv
La nuova tv

ZUPPE
MISTO
ASPAGNO
L'aitle alla
le sei diverse
Zuppe Cir

Una famiglia di lampade in metallo cromato, con una base in resina epossidica nella quale sono immersi fogli di riviste originali d'epoca. Attacco predisposto per lampadine E27.

A family of luminaires made of chrome-coated metal, with an epoxy resin base, encompassing pages of original old magazines. It features a light socket for E27 lamps.



L'attacco E27 dell'articolo offre la possibilità di installare una lampadina con qualsiasi sorgente.

The E27 socket of the article allows the choice of lamps with any light source.

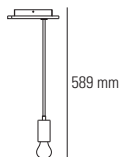

7454 cromo / chrome
E27 1x42W 240V

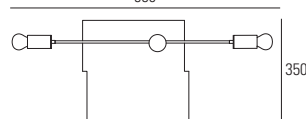
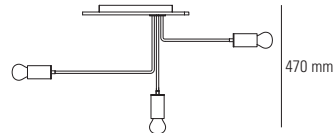

7455 cromo / chrome
E27 3x42W 240V

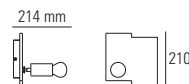

7450 cromo / chrome
E27 1x42W 240V



KIT69 cromo / chrome
oscurante





La base in resina ingloba fogli di riviste originali degli anni '40-'80: pertanto ogni articolo prodotto a mano è un pezzo unico.

The resin base encompasses pages of original magazines of the 40's-80's: therefore each article produced by hand is unique.

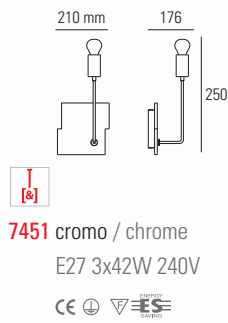
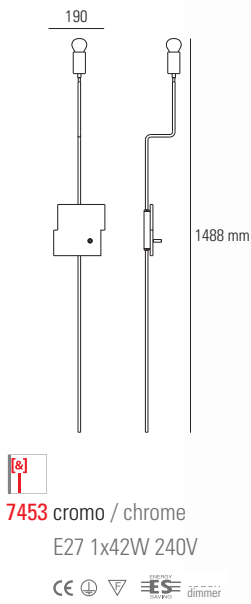

KIT69 cromo / chrome
oscurante

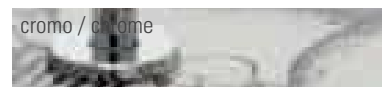





Dimmer

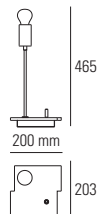

 **7452** cromo / crome
 E27 1x42W 240V
   dimmer

KIT69 cromo / chrome
 oscurante

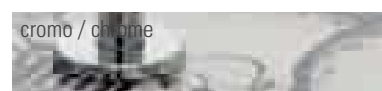





FANTASIA E CAPACITÀ TECNICA CONSENTONO DI INVENTARE OGGETTI NUOVI, ESPRESSIONE D'UNICITÀ ALL'INTERNO DI UN PROGETTO PARTICOLARE. LE NECESSITÀ ED IL GUSTO DEL CLIENTE SI TRASFORMANO IN ARTICOLI D'ILLUMINAZIONE PERSONALIZZATI: LUCE, MATERIALE, ESTETICA VENGONO RIMODELLATI DA LINEA LIGHT GROUP SEGUENDO L'IDEA DI PROGETTISTI E LIGHTING DESIGNER.

IMAGINATION CRÉATIVE ET MAÎTRISE TECHNIQUE SONT À L'ORIGINE DE NOUVEAUX OBJETS, EXPRESSION D'UNICITÉ AU SEIN D'UN PROJET SPÉCIAL. LES EXIGENCES ET LE GOÛT DU CLIENT SE TRANSFORMENT EN ARTICLES D'ÉCLAIRAGE PERSONNALISÉS : LUMIÈRE, MATÉRIEL, ESTHÉTIQUE SONT REMODELÉS PAR LINEA LIGHT GROUP SUIVANT L'IDÉE DES CONCEPTEURS ET DES DESIGNERS ÉCLAIRAGISTES.

FANTASIE UND TECHNISCHES FACHWISSEN SCHAFFEN DIE VORAUSSETZUNGEN FÜR DIE ENTWICKLUNG NEUER OBJEKTE ALS AUSDRUCK DER EINZIGARTIGKEIT IM RAHMEN EINES GANZ BESONDEREN PROJEKTS. DIE ANFORDERUNGEN UND DER GESCHMACK DES KUNDEN WERDEN IN PERSONALISIERTE BELEUCHTUNGSARTIKEL UMGESETZT: LICHT, MATERIAL UND ÄSTHETIK WERDEN VON DER LINEA LIGHT GROUP ANHAND DER IDEEN VON PROJEKTPLANERN UND LIGHTING DESIGNERN GESTALTET.

CREATIVITY AND TECHNICAL SKILLS TOGETHER MAKE IT POSSIBLE TO CREATE NEW OBJECTS THAT EXPRESS THEIR UNIQUENESS IN EVERY SINGLE PROJECT. THE NEEDS AND TASTE OF THE CLIENT ARE TRANSFORMED INTO CUSTOMISED LIGHTING ARTICLES: LIGHT, MATERIAL, AND AESTHETICS ARE REMODELLED BY LINEA LIGHT GROUP FOLLOWING THE IDEA OF PLANNERS AND LIGHTING DESIGNERS.

FANTASÍA Y CAPACIDAD TÉCNICA PERMITEN INVENTAR OBJETOS NUEVOS, EXPRESIÓN DE UNICIDAD EN EL SENO DE UN PROYECTO ESPECIAL. LAS NECESIDADES Y EL GUSTO DEL CLIENTE SE TRANSFORMAN EN OBJETOS DE ILUMINACIÓN PERSONALIZADOS: LUZ, MATERIAL Y ESTÉTICA SON REMODELADOS POR LINEA LIGHT GROUP SIGUIENDO LA IDEA DE PROYECTISTAS Y DISEÑADORES DE ILUMINACIÓN.

ФАНТАЗИЯ И ТЕХНИЧЕСКИЕ ВОЗМОЖНОСТИ ПОЗВОЛЯЮТ СОЗДАВАТЬ НОВУЮ ПРОДУКЦИЮ, ПРИДАЮЩУЮ КАЖДОМУ ИНДИВИДУАЛЬНОМУ ПРОЕКТУ ОСОБУЮ УНИКАЛЬНОСТЬ. ТРЕБОВАНИЯ И ПРЕДПОЧТЕНИЯ КЛИЕНТА ПРЕВРАЩАЮТСЯ В ПЕРСОНАЛИЗИРОВАННЫЕ СВЕТОВЫЕ ПРИБОРЫ; СВЕТ, МАТЕРИАЛ И ВНЕШНИЙ ВИД ПЕРЕМОДЕЛИРУЮТСЯ КОМПАНИЕЙ LINEA LIGHT GROUP В СООТВЕТСТВИИ С ЗАДУМКОЙ ПРОЕКТИРОВЩИКОВ И ДИЗАЙНЕРОВ-СВЕТОТЕХНИКОВ.

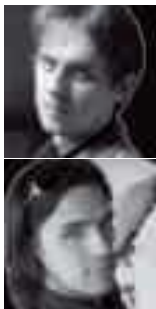

ANTON PETROV

Vincitore di prestigiosi concorsi Russi di architettura e design tra i quali quello indetto da Manàmanà per l'innovativo design della lampada DUNIA, Anton Petrov nasce a Mosca nel 1978 e studia all'Istituto di Arti Applicate dove si diploma nel 1996. La sua formazione artistica prosegue con gli studi all'università "Arti e Industria" Straganov di Mosca dove nel 2002 riceve la laurea. Subito dopo, nel 2003, diventa membro dell'Unione degli Artisti di Mosca e partecipa a numerose esposizioni d'arte. Lavora e collabora come designer per importanti aziende come "Pioneer" e "Cherkizovsky Meat Processing Plant" creando nuovi brands per i quali ha ricevuto prestigiosi riconoscimenti, e come architetto in prestigiosi studi come "Casa Nova" e "ODS Laboratory" del quale è fondatore.

Winner of prestigious Russian competitions of architecture and design including the one announced by Manàmanà for the innovative design of the lamp DUNIA, Anton Petrov was born in Moscow in 1978 and studied at the Institute of Applied Arts where he graduated in 1996. His artistic education continued with studies at the University "Art and Industry" Straganov Moscow where in 2002 he received his degree. Soon after, in 2003, he became a member of Moscow Union of Artists and he participated to numerous art exhibitions. He works and collaborates as designer for important companies such as "Pioneer" and "Cherkizovsky Meat Processing Plant" creating new brands for which he has received prestigious awards, and as architect in prestigious studios as "Casa Nova" and "ODS Laboratory" which is the founder.



EDIN DEDOVIC

Nato in Bosnia-Erzegovina nel 1984, si diploma presso l'Istituto tecnico di Castelfranco Veneto nel 2005 ed inizia la collaborazione con LineaLight come progettista tecnico sviluppando decine di articoli in collaborazione con i designer. Dal 2009 disegna alcuni prodotti come "Move", "Snake", "Wings" e si applica nel campo della ricerca di materiali e nuove tecnologie disegnando in occasione del L&B 2012 la lampada OLED "Sweet Light" in collaborazione con il produttore Lumiotec.

Born in Bosnia and Herzegovina in 1984, he attended the technical high school in Castelfranco Veneto (Italy) and obtained his diploma in 2005. He then began working as technical designer at LineaLight, where he developed dozens of items in collaboration with the designers. In 2009 he designed products such as "Move", "Snake" and "Wings", and began focusing on research applied to materials and new technologies; during this period, he designed the "Sweet Light" OLED lamp for the L&B 2012 fair, in collaboration with the manufacturer Lumiotec.



LUCA TURRINI

(1962) – Light Design & Art Director

Formazione di estrazione tecnica, sviluppa la passione per l'illuminazione fin dai primi anni nel mondo del lavoro. Inizia in Sirrah, azienda leader negli anni '80 per industrializzazione e design di illuminazione. Dallo stretto contatto con grandi maestri, architetti e professionisti, quali Emilio Ambasz, Dino Gavina, Kazuhide Takahama, Renè Kemna, King & Miranda, artefici della ampia creatività di quegli anni e precursori dei successivi, sviluppa sensibilità e grande attitudine al design. Conosce Bruno Munari e collabora alla realizzazione delle "Sculpture da viaggio" per Sirrah, opere in edizione limitata.

Alla iGuzzini illuminazione con il loro staff tecnico matura specifica esperienza nell'illuminazione tecnica e per esterni, entra poi in un importante gruppo commerciale di distribuzione, sviluppa il concetto della progettazione illuminotecnica intesa come assistenza al progettista, diviene "opinion leader" del settore luce e persona di riferimento tecnico/artistico del gruppo. Crea e cura l'house organ aziendale e lo redige in prima persona. Sviluppa un nuovo concept per l'illuminazione degli esterni, trasportando il concetto di "cestello" (batterie di proiettori tradizionalmente per illuminazione scenica di interni) in outdoor. Nel 2008 realizza il Format Design Studio, struttura professionale di progettazione illuminotecnica, tra i primi studi in Italia con lo scopo di supportare i progettisti, strutturisti, architetti e dare un valore aggiunto alla progettazione architettonica unita all'illuminotecnica.

Sempre in contatto con le migliori aziende di settore affina le proprie capacità personali ed illuminotecniche, condividendo esperienze a livello internazionale. Il Design rimane materia fondamentale di studio e passione, che gli permette di disegnare molteplici prodotti, proposti e prodotti oggi da aziende leader di settore. Ottiene anche diversi riconoscimenti tra i quali due RED DOT DESIGN AWARD (2009 e 2010) con ARTEMIDE.

Unitamente all'attività di progettazione illuminotecnica, collabora con aziende di settore analizzando le esigenze del mercato per soddisfarle con le nuove proposte.

Endowed with a technical background, he developed a passion for illumination ever since embarking on his professional career. He began his career at Sirrah, a leading company throughout the 1980s specialising in lighting industrialisation and design. By cooperating closely with renowned masters, architects and professionals such as Emilio Ambasz, Dino Gavina, Kazuhide Takahama, Renè Kemna, King & Miranda - the in-

ventors of the sweeping creativity characterising those years and the forerunners of the successive era - he developed his sensitivity and distinctive flair for design. He then met Bruno Munari and collaborated in the creation of the "Sculpture da viaggio" ("pocket sculptures") project for Sirrah, a limited-edition work.

Working with the technical staff at iGuzzini Illuminazione enabled him to acquire specific experience in technical lighting for outdoor applications, before moving to an important commercial group specialising in distribution: here he developed a lighting design approach based on assistance to the designer, and became an opinion leader in the lighting sector and the group's technical/artistic reference. He created the company's house organ, which he also managed and personally edited. He then developed a new concept for outdoor illumination by adopting - for outdoor applications - the system based on batteries of spotlights traditionally used for scenic indoor illumination.

In 2008 he created the Format Design Studio, a professional lighting design facility which was among the first studios in Italy aimed at supporting designers, structurists and architects, while enhancing architectural design with lighting solutions.

By maintaining close relations with the foremost companies in the sector, he was able to refine his own personal abilities and lighting design skills while sharing experiences at an international level. Design continues to be a fundamental subject of his studies and passion and, as a result, he has designed multiple products that have been proposed and manufactured by the leading companies in the sector. He has also received several acknowledgements, including the RED DOT DESIGN AWARD (2009 and 2010) with ARTEMIDE.

Alongside his lighting design activity, he also collaborates with companies in the sector in analysing market needs and proposing new solutions for satisfying them.



MANUEL REMEGGIO

Nel 1996 si Diploma presso il Liceo Artistico di Treviso.

Nel 2000 studia presso la Middlesex University Fine Art Londra. Dopo la Laurea in Arti Visive all'Accademia di Belle Arti di Venezia nel 2003 è Creative Director per CERTRE' www.certre.com e realizza il Programma Life Style di design ceramico.

2008/2010 Ha disegnato per il nuovo brand di Linea Light MADE Folia, Mamba.

2008/09 Ha disegnato per Manamanà, nuovo brand del Gruppo LineaLight www.linealight.com, prodotti sia per l'interno che per l'esterno a basso consumo, tavoli, sedute, pianthane in rotazionale a led.

2010 art director Manamanà a brand of Linea Light, disegna i nuovi articoli "I Boteri" e disegna la sospensione "Binibiru" a led e in vinile. Progetta il Light Village 1400mq laboratorio di luce del Gruppo.

2011 Cura l'immagine aziendale del Gruppo Linealight. Fonda la rivista di luce Snapshots.

In 1996 he graduated from the Art School of Treviso.

In 2000 he studied Fine Art at Middlesex University, London. After graduating in Visual Arts at the Accademia di Belle Arti of Venice in 2003, he became Creative Director for CERTRE' www.certre.com and realised the Life Style Programme of ceramic design.

2008/2010 He designed the Folia and Mamba lines for MA&DE, the new brand of Linea Light.

2008/09 He designed for Manamanà, the new brand of Linea Light Group www.linealight.com Light, products both for indoor and outdoor use marked by low consumption, consisting of tables, chairs, floor lights made with rotational moulding and I-LèD technology.

2010 art director of the Manamanà brand of Linea Light, he designed the new product line "I Boteri" and the ceiling light "Binibiru" based on I-LèD technology and made with vinyl. He designed the Light Village, the 1400 sqm Light Laboratory of the Group.

2011 He takes care of the corporate image of LineaLight Group. He founded the lighting magazine Snapshots, and plans the advertising campaigns.



MIRCO CROSATTO

Nasce a Treviso il 28 settembre 1976 si diploma all'istituto

tecnico a Treviso, a 16 anni collabora con un'azienda di StreetWear di Treviso. Finiti gli studi, nel 1997 incomincia l'esperienza lavorativa alla Linealight, nel corso degli anni sviluppa numerosi articoli, nel nuovo brand di linea light Made disegna l'O-line, il Mr-Magoo, e la Lama vincitrice del premio Reddot design award 2011.

Was born in Treviso on 28 September 1976. Graduated at the Technical Institute in Treviso, at 16 collaborates with a street wear company in Treviso. After finishing his studies in 1997 begins his work experience with Linealight, over the years has developed several articles, and with the new Linealight's brand MaDe draws the O-line, the Mr-Magoo and the Lama, RedDot design award 2011 winner.



ORIANO FAVARETTO

Nasce a Treviso nel 1956. L'ambiente in cui vive, attrav-

verso le sue peculiari caratteristiche sociali e geografiche, contribuisce in maniera decisiva a plasmare profondamente la sua personalità, il suo gusto artistico e la sua carriera. Frequenta il Liceo Artistico e successivamente l'Accademia delle Belle Arti all'interno della quale ha occasione di conoscere e confrontarsi con Emilio Vedova, prezioso maestro di gesti e di segni nonché artista e docente di fama internazionale. Un'altra importante esperienza che lascia un segno indelebile è data dalla collaborazione con Ennio Chiggio, del quale diviene apprendista e collaboratore. Tra i suoi maggiori successi professio-

nali si possono annoverare il riconoscimento al "Concorso tra Accademie" d'Italia, il Premio "Lubiam 1982" e l'esperienza pittorica maturata presso la fondazione "Bevilacqua La Masa". Oriano Favaretto ha preso parte ad importanti rassegne internazionali tra le quali "Eventi" a Milano con Zuccheri and Oira, la mostra itinerante "I Fiori della Metafora" con Plessi e D'Orazio ed il premio "Murano" vinto nel 1987 e nel 1992. Selezionato inoltre nel concorso degli affreschi per Sacca Fisola Venezia. Di grande rilievo il premio "Lampada d'Oro" del S.I.L. di Parigi nel 1993. Nel 1997 la rivista Marie Claire gli conferisce il "Prix d'Excellence" alla sua "Polipò" che diventa così lampada dell'anno.

collabora con numerose aziende di spicco nell'ambito del design industriale come ad esempio Boss, Artemide, ITre, De Majo, BRF, Venini, Fabbian (2004), Viabizzuno ,mastella bagni , regia.pom dor Attualmente svolge la funzione di Art Director presso Mastella Bagni di Treviso. Le sue opere artistiche sono esposte al Museo del Vetro di Murano e presso molte collezioni private.

He was born in Treviso in 1956.

The environment in which he lived - owing to its distinctive social and geographic features - left a deep impression on his personality, artistic taste and career.

After attending art school, he enrolled with the fine arts academy where he was able to meet and exchanged views with Emilio Vedova, a valuable master of gestures and signs who is also a world-renowned artist and lecturer.

Another important experience that left an indelible mark was the collaboration with Ennio Chiggio, of which he became apprentice and collaborator.

His greatest professional successes include an award at the "Concorso tra Accademie d'Italia", the "Lubiam 1982" Award and the painting experience at the "Bevilacqua La Masa" foundation.

Oriano Favaretto has participated in important international exhibitions, including "Eventi" in Milan with Zuccheri and Oira, the travelling exhibition "I Fiori della Metafora" with

Plessi and D'Orazio, and the "Murano" Award which he received in 1987 and 1992.

Moreover, he was chosen for the fresco contest for Sacca Fisola in Venice. Another significant achievement was the "Lampada d'Oro" Award which he received at the S.I.L. trade show in Paris in 1993.

In 1997, the magazine "Marie Claire" awarded him the "Prix d'Excellence" for "Polipò", which was designated lamp of the year.

He collaborates with several leading companies in the industrial design scenario, including Boss, Artemide, ITre, De Majo, BRF, Venini, Fabbian (2004), Viabizzuno, Mastella Bagni, regia.pom dor, and others.

He currently works as Art Director at Mastella Bagni based in Treviso.

His artistic works are displayed at the "Museo del Vetro" glass museum in Murano and in numerous private collections.

STUDIO MATHESIS2012

Nel 2001, dall'incontro tra Annarosa Romano e Bruno Menegon, nasce lo Studio Mathesis2012. Negli anni lo Studio cresce grazie alla partecipazione di altri professionisti legati dalla passione di sviluppare dei progetti originali nel settore dell'illuminazione e dei componenti d'arredo. Attraverso la collaborazione con numerose aziende, tra le quali Carlo Moretti di Venezia, Modo Luce, Flaver, A D, Progetti, Linea Light, inizia un percorso di ricerca di nuovi materiali e tecniche per dei prodotti armoniosi ed eleganti.

In 2001, the encounter between Annarosa Romano and Bruno Menegon led to the opening of the Mathesis 2012 studio. Over the years, the studio grew thanks to the participation of other professionals united by a mutual passion for developing original projects in the lighting and furnishing components sector. The collaboration with several companies - among them Carlo Moretti of Venice, Modo Luce, Flaver, A D, Progetti, Linea Light - sparked a research activity focusing on new materials and techniques for developing harmonious, elegant products.

RIVISTE, CATALOGHI, SITI WEB DEL MONDO DEL DESIGN ITALIANO ED INTERNAZIONALE DIVENTANO NATURALI VETRINE DELLO STILE E DELL'INVENTIVA DEL BRAND MA&DE. IL PIACERE DI CREARE LUCE DI LINEA LIGH GROUP TROVA SPAZIO IN PUBBLICAZIONI DI LIGHTING DESIGN, INTERIOR DESIGN, ARCHITETTURA.

MAGAZINES, CATALOGUES, WEB SITES OF THE ITALIAN AND INTERNATIONAL DESIGN WORLD BECOME NATURAL SHOWCASES OF THE STYLE AND CREATIVITY OF THE MA&DE BRAND. THE LOVE FOR CREATING LIGHT THAT CHARACTERISES LINEA LIGH GROUP APPEARS THROUGH THE PAGES OF PUBLICATIONS BELONGING TO THE LIGHTING DESIGN, INTERIOR DESIGN, AND ARCHITECTURE SECTORS.

REVUES, CATALOGUES, SITES WEB DU MONDE DU DESIGN ITALIEN ET INTERNATIONAL SE TRANSFORMENT EN DE VÉRITABLES VITRINES DU STYLE ET DE L'INGÉNIOSITÉ DE LA MARQUE MA&DE. LE PLAISIR DE CRÉER LA LUMIÈRE QUI ANIME LINEA LIGH GROUP TROUVE PLACE DANS DES PUBLICATIONS DE CONCEPTION D'ÉCLAIRAGE, DE DÉCORATION D'INTÉRIEUR ET D'ARCHITECTURE.

LEONARDO CASE&STILI N. 1 DICEMBRE 2011 -GENNAIO 2012. - WWW.IL-
E CASALI N. 43 GENNAIO -FEBBRAIO 2012. - WWW.ROERO-ILLUMINAZIONE.
ONE N. 3 MARZO 2012. - ACQUA CORRENTE N. 1 MARZO 2012. - WWW.
2012. - WWW.MYSMARTHOTEL.NET MARZO 2012. - IL SOLE 24 ORE SUPPL.
LIGHTING N. 117 MARZO -APRILE 2012. - HOME COMFORT & DESIGN N.
APRILE 2012. - COSE DI CASA N. 4 APRILE 2012. - DDN N. 184 APRILE 2012. -
N. 2 APRILE 2012. - CHEF N. 16 APRILE 2012. - SUITE N. 159 APRILE 2012. - VERO CASA N. 4 APRILE 2012. - CASAVIVAMAGAZINE MAG-
LEDIN.IT MAGGIO 2012. - LIGHTING MAGGIO 2012. - WWW.LIGHTIS.EU MAGGIO 2012. - WWW.PORTEDILO.IT MAGGIO 2012. - WWW.
2012. - WWW.SCOOP.IT MAGGIO 2012.
NESSERE.IT MAGGIO 2012. - CASA NATU-
2012. - ELETTRONICA N. 5 MAGGIO 2012. - TO-
2012. - ITALIAN LIGHTING N. 178 MAG-
- DENTRO CASA GIUGNO 2012. - LUCE &
IT GIUGNO 2012. - CASA IN FIORE N. 6
COM LUGLIO 2012. - WWW.INFOBUILD.IT
2012. - WWW.ROERO-ILLUMINAZIONE.IT
8 LUGLIO -AGOSTO 2012. -**OTTAGONO N. 252 LUGLIO -AGOSTO 2012.**



LUMINOTECNICA COM GENNAIO 2012. - I
IT FEBBRAIO 2012. - CASE & STILI N. 2 FE
ELETTRICOPUS.IT MARZO 2012. - WWW.I
CASA24PLUS 1 MARZO 2012. - LA TRIBUN
41 MARZO -APRILE 2012. - GENTE N. 17 24



- **CASABELLA N. 812 APRILE 2012.** - L'IMPIANTO ELETTRICO
N. 2 APRILE 2012. - CASAVIVAMAGAZINE MAG-
LEDIN.IT MAGGIO 2012. - WWW.LIGHTIS.EU MAGGIO 2012. - WWW.
2012. - WWW.SCOOP.IT MAGGIO 2012.
- COMPOARREDO N. 71 MAGGIO 2012. - OTTAGONO N. 250
RALE N. 47 MAGGIO 2012. - DESIGN & ARREDO N. 2 MAGGIO
TAL LIGHTING MAGGIO 2012. - ENERGIA SOLARE & RINNO-
GIO -GIUGNO 2012. - DHD N. 30 GIUGNO -LUGLIO -AGOSTO
DESIGN N. 3 GIUGNO 2012. - **CASE & STILI N. 6 GIUGNO 2012.**
GIUGNO 2012. - VERO CASA N. 6 GIUGNO 2012. - MONDO ARC GIUGNO -LUGL
LUGLIO 2012. - WWW.LAVORINCASA.IT LUGLIO 2012. - WWW.LEDIN.IT LUGLI
LUGLIO 2012. - WWW.YOUFEED.IT LUGLIO 2012. - ELETTRONICA & IMPRESE L



THEY TALK ABOUT OUR DESIGN

REVISTAS, CATÁLOGOS Y SITIOS WEB DEL MUNDO DEL DISEÑO ITALIANO E INTERNACIONAL SE CONVIERTEN EN ESCAPARATES NATURALES DEL ESTILO Y LA INVENTIVA DE LA MARCA MA[&]DE. EL PLACER DE CREAR LUZ DE LINEA LIGHT GROUP ENCUENTRA ESPACIO EN PUBLICACIONES ESPECIALIZADAS EN DISEÑO DE ILUMINACIÓN, DISEÑO DE INTERIORES Y ARQUITECTURA.









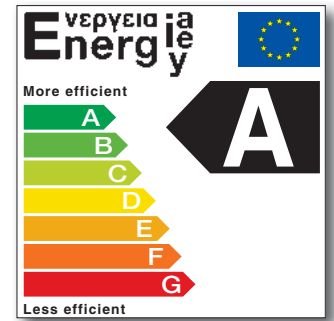







ZEITSCHRIFTEN, KATALOGE UND WEBSITES AUS DER WELT DES ITALIENISCHEN UND INTERNATIONALEN DESIGNS WERDEN ZUR NATÜRLICHEN BÜHNE FÜR DEN STIL UND ERFINDUNGSREICHTUM DER MARKE MA[&]DE. DIE BEGEISTERUNG, MIT DER DIE LINEA LIGHT GROUP BELEUCHTUNGEN SCHAFFT, WIRD VON ZAHLREICHEN VERÖFFENTLICHUNGEN IN DEN BEREICHEN LIGHTING DESIGN, INNENARCHITEKTUR UND ARCHITEKTUR BELEGT.

ЖУРНАЛЫ, КАТАЛОГИ, ВЕБ САЙТЫ ВО ВСЕМ МИРЕ, ПОСВЯЩЕННЫЕ ИТАЛЬЯНСКОМУ И МИРОВОМУ ДИЗАЙНУ, СТАНОВЯТСЯ ЕСТЕСТВЕННЫМИ ВИТРИНАМИ СТИЛЯ И ИЗОБРЕТАТЕЛЬНОСТИ БРЕНДА MA[&]DE. РАДОСТЬ, КОТОРУЮ КОМПАНИЯ LINEA LIGHT GROUP ПОЛУЧАЕТ ОТ СОЗДАНИЯ СВЕТА, НАХОДИТ СВОЕ ВЫРАЖЕНИЕ В РАЗЛИЧНЫХ ИЗДАНИЯХ, ПОСВЯЩЕННЫХ СВЕТОВОМУ ДИЗАЙНУ, ДИЗАЙНУ ИНТЕРЬЕРА И АРХИТЕКТУРЕ.

LOVE SICILIA GENNAIO 2012. - GD'A N. 1 GENNAIO 2012. - DOMUS N. 954 GENNAIO 2012. - WWW.DOMUSWEB.IT GENNAIO 2012. - RISTRUTTURAZIONE FEBBRAIO 2012. - WWW.BLOG.BAGNOITALIANO.IT MARZO 2012. - CORRIERE DELLA SERA 15 MARZO 2012. - ASTRA N. 3 MARZO 2012. - ELETTRIFICAZIONE INTERNIMAGAZINE.IT MARZO 2012. - WWW.MONDOARC.COM MARZO 2012. - WWW.VIAGGIINBENESSERE.IT MARZO 2012. - IL GAZZETTINO 4 MARZO A DI TREVISO 16 MARZO 2012. - COME RISTRUTTURARE LA CASA N. 2 MARZO -APRILE 2012. - ITALIAN LIGHTING N. 117 MARZO -APRILE 2012. - ITALIAN LIGHTING N. 118 APRILE 2012. - YOU TRADE N. 30 APRILE 2012. - LED IN MAGAZINE N. 2 APRILE 2012. - LED IN MAGAZINE N. 2 APRILE 2012. - LED IN MAGAZINE N. 2 APRILE 2012. - DOMOTICO APRILE 2012. - COMMERCIO ELETTRICO N. 3 APRILE 2012. - WATT ELETTOFORNITURE MAGGIO 2012. - WWW.ILNORD.COM MAGGIO 2012. - WWW.INFOBUILD.PLACESWEB.NET MAGGIO 2012. - WWW.RUGIADAPOINT.IT MAGGIO MAGGIO 2012. - CASE & STILI N. 5 MAGGIO 2012. - WWW.VIAGGIINBENESSERE.IT MARZO 2012. - GIE IL GIORNALE DELL'INSTALLATORE ELETTRICO N. 4 MAGGIO MAGGIO 2012. - VABILI N. 3 MAGGIO -GIUGNO 2012. - LED'S N. 18 MAGGIO -GIUGNO 2011. - NATURAL STYLE GIUGNO 2012. - INTERNI N. 6 GIUGNO 2012. - ATTUALITA' ELETTEOTECNICA N. 5 GIUGNO 2012. - WWW.THEPLAN.INTERNI N. 7 GIUGNO 2012. - DEAR DESIGN & ARREDO N. 3 GIUGNO -LUGLIO 2012. - SUITE N. 160 LUGLIO 2012_ WWW.ILLUMINOTECNICA.IT LUGLIO 2012. - WWW.MYSMARTHOTEL.NET LUGLIO 2012. - DENTRO CASA N. 152 LUGLIO 2012. - WWW.PORTEDILO.IT LUGLIO LUGLIO 2012. - VERO CASA N. 7 LUGLIO 2012. - MARIE CLARE MAISON N. 7 LUGLIO -AGOSTO 2012. - DOMUS N. 960 LUGLIO -AGOSTO 2012. - INTERNI N. 7 AGOSTO 2012.





	Simbolo Symbol	Attacco Socket	Potenza Output	Voltaggio Voltage	Intensità Flusso Flux Intensity	Vita Media Ore Hour Average Duration	ILCOS Code	Classe Ener- getica Energy Class	Codice Code	
Lampade alogene Halogen lamps		E27	42 W	240 V	630 LM	1000	IRR		—	
			52 W		840 LM				—	
			70 W		1240 LM				—	
			105 W		1900 LM				—	
		G9	20 W	240 V	200 LM	2000	HSG		042200	
			33 W		460 LM				—	
			48 W		740 LM				04300	
			60 W		980 LM				04400	
Lampade Fluorescenti Flourescent lamps		E27	11 W	240 V	630 LM	15000	FBA		00400	
			17 W		950 LM				00500	
			20 W		1200 LM				—	
			24 W		1500 LM				00600	
			2G10	36 W	240 V	2800 LM	15000	FSD		N2103-9
				24 W		1200 LM				18000
			2GX13	22 W	240 V	1800 LM	18000	FC		N2100-9
				55 W		4200 LM				18000
		G5	39 W	240 V	3500 LM	20000	FD		061000	
			9 W		220 LM				15000	
Lampade LED LED lamps		E27	5 W 180° Warm White	240 V	300 LM	20000			093000	
		E27	8 W 180° Warm White		500 LM				20000	

Eco+

"Il nostro impegno per un mondo più luminoso e pulito"

"our commitment for a brighter, cleaner world"

"notre engagement pour un monde plus lumineux et propre"

"nuestro compromiso por un mundo más luminoso y limpio"

"Wir engagieren uns für eine leuchtende und saubere Welt"

"Наша задача для мира более светлого и чистого"

G9 Fluo Eco+
G9 9W 4000K 230V
Code: **011000056000**
Compatibility:

- Square:
6624, 6626, 6627
- Ottagono:
7086, 7088





Sospensione
Hanging lamp



Lampada da terra
Floor lamp



Lampada da parete
Wall lamp



Lampada da parete
Wall lamp



Plafoniera
Ceiling lamp



Lampada da tavolo
Table lamp



La marcatura CE è un'autocertificazione la quale definisce che i prodotti di LINEA LIGHT s.r.l., sono tutti verificati in base alle norme prescritte:

The CE mark is a self-certification which defines all LINEA LIGHT s.r.l. products as conforming with the following norms:

CEI EN 60598- 1
prescrizioni generali e prove
general requirements and tests

CEI EN 60598- 2-1
apparecchi fissi per uso generale
fixed equipment for general use

CEI EN 60598- 2-4
apparecchi di illuminazione mobili
di uso generale
mobile lighting equipment for
general use

CEI EN 60598- 2-
proiettori
projector lights



CLASSE I

Apparecchi con parti metalliche costantemente collegate al circuito di terra.

Equipment with metal parts constantly connected to the earth circuit.



CLASSE II

Apparecchi con parti in tensione isolate fra loro e verso l'esterno con un doppio isolamento e senza dispositivi di messa a terra.

Equipment with live parts insulated from one another and from the outside with double insulation and without earthing devices.



Apparecchi idonei per essere montati su superfici normalmente infiammabili.
Equipment suitable to be fitted on normally inflammable surfaces.

IP ...

La "resistenza" offerta dall'apparecchio alla penetrazione di solidi e liquidi viene indicata dal prefisso IP (International Protection) seguita da due cifre significative. La prima cifra identifica il grado di protezione contro l'ingresso di corpi solidi.

The resistance of the fitting to the penetration of solids and liquids is stated by the code IP (International Protection) followed by two significant numbers. The first number identifies the protection degree against the entry of solid bodies.

CEI EN 60598- 2-6
apparecchi di illuminazione con trasformatore incorporato per lampade ad incandescenza
lighting equipment with built-in transformer for incandescent lamps

CEI EN 60598- 2-10
apparecchi mobili tipo giocattolo
mobile equipment, e.g. toys

CEI EN 60598- 2-23
sistemi di illuminazione a bassissima tensione per lampade ad incandescenza
very low voltage lighting systems for incandescent lamps

IP 2...
Protetto contro la penetrazione di corpi liquidi di dimensioni superiori a 12 mm.
Protected against the entry of solid bodies with dimensions of more than 12 mm.

IP 3...
Protetto contro la penetrazione di corpi solidi di dimensioni superiori a 2,5 mm.
Protected against the entry of solid bodies with dimensions of more than 2,5 mm.

IP 4...
Protetto contro la penetrazione di corpi solidi di dimensioni superiori a 1 mm.
Protected against the entry of solid bodies with dimensions of more than 1 mm.

La seconda cifra identifica il grado di protezione contro l'ingresso di corpi liquidi.
The second number identifies the protection degree against the entry of liquids.

IP ...0
Non protetto.
Unprotected.

IP ...1
Protetto contro le cadute verticali di gocce d'acqua.
Protected against the vertical falling of water drops.

IP ...2
Protetto contro la caduta dell'acqua con inclinazione massima di 15°.
Protected against the falling of water with a maximum inclination of 15°.

IP ...3
Protetto contro la pioggia.
Protected against rain.

IP ...4
Protetto contro gli spruzzi.
Protected against sprinklings.

IP ...5
Protetto contro i getti d'acqua.
Protected against water jets.

IP ...6
Protetto contro le ondate.
Protected against heavy waves.



Trasformatore
alimentatore elettronico.
Light distribution patterns.



Risparmio energetico.
Energy saving.



Filo incandescente a 850° C
Glow wire test at 850° C



Dimmer
Dimmable

touch
dimmer

Dimmeratore touch.
Touch dimmer.

dimmer

Dimmeratore.
Dimmer.

CODICE / CODE	PAG	CODICE / CODE	PAG	CODICE / CODE	PAG
6575	126	6834	58	7073	64
6576	126	6848	56	7074	64
6578	128	6855	94	7075	62
6579	124	6856	98	7076	62
6587	126	6857	98	7077	62
6588	126	6858	94	7078	62
6590	126	6859	94	7079	60
6591	126	6860	94	7080	60
6593	126	6861	86	7081	110
6594	126	6862	86	7082	110
6596	128	6863	86	7086	114
6597	128	6864	86	7087	114
6599	124	6865	86	7088	114
6600	124	6866	86	7089	112
6624	126	6867	88	7100	28
6626	126	6868	88	7102	28
6627	126	6869	88	7103	28
6670	74	6871	86	7105	30
6671	74	6872	86	7106	32
6672	76	6873	86	7108	32
6673	76	6875	106	7109	32
6674	74	6876	106	7111	32
6675	74	6877	106	7112	30
6676	76	7065	60	7114	30
6677	76	7066	60	7116	36
6830	58	7069	64	7117	36
6831	58	7070	64	7118	34
6832	56	7071	56	7119	34
6833	58	7072	56	7126	118

CODE - PAGE

CODICE / CODE	PAG	CODICE / CODE	PAG
7128	118	7431	42
7129	120	7433	82
7131	120	7434	82
7132	120	7435	80
7134	120	7441	68
7166	90	7442	68
7167	90	7443	70
7168	90	7444	70
7171	90	7445	68
7172	90	7450	132
7173	90	7451	134
7176	88	7452	136
7177	88	7453	134
7178	88	7454	132
7411	52	7455	132
7412	52	7460	16
7414	52	7461	18
7415	52	7462	16
7420	40	7463	18
7421	40	7465	24
7422	44	7466	24
7423	44	7470	102
7424	44	7471	102
7425	44	7472	102
7426	46	7473	102
7427	46	KIT69	132-136
7428	46		
7429	46		
7430	42		

Thanks:

Arrital: www.arritalcucine.com

Etrastudio: www.etrastudio.com

Gianluca Pelloia: www.gianlucaelloia.it

Martex: www.martex.it

Melody cucine: www.melodycucine.com

Tubes: www.tubesradiatori.com

Il presente catalogo è tutelato dalla legge sui diritti d'autore (legge 22/4/1941 n° 633 e dalla legge 14/12/1942 n° 1485: di esso è proibita ogni riproduzione totale o anche parziale.)

This catalogue is safeguarded by the law on copyright (law 22/4/1941 no. 633 and by the law 14/12/1942 no. 1485: all total or even partial reproductions of the catalogue are forbidden.



© Linea Light Group

Concept and Impagination: marketing department Linea Light Group

Fotolito: www.creativestudiosrl.it

Photo: Luigi De nadai

Print: Graficart

Finished printing: August 2012

I disegni, le quote, i materiali ed i colori degli articoli del presente catalogo si intendono a titolo indicativo. Nell'interesse della clientela l'azienda si riserva il diritto di modificare i modelli in ogni momento senza obbligo di preavviso.

Drawings, quotations, materials and colours of this catalogue are only for information.

For customer's interest the company could modify the items without any previous notice.



Sede Operativa

Via della Fornace, 59 z.l.
I - 31023 Castelminio di Resana
Treviso - Italy

Ufficio Vendite Italia

Tel. + 39 0423 78 68
Fax + 39 0423 78 69 00
sales@linealight.com

Post-Vendita

daims@linealight.com
assistenza@linealight.com

Sede Legale & Amministrativa

Via Caf Longa, 7 z.l.
I - 31028 Vazzola (TV)
Tel. + 39 0438 44 48 26
Fax + 39 0438 44 48 50
www.linealight.com

Export Sales Dept.

Tel. + 39 0423 78 68
Fax + 39 0423 78 69 99
customer.service@linealight.com

Linea Light France

Z.A. Helden Est, 12 Rue des Pays-bas
68310 Wittelsheim - France
Tel. + 33 389 755223
Fax + 33 389 755907
info@linealight.fr